



UNIVERSIDAD
Finis Terrae

UNIVERSIDAD FINIS TERRAE
FACULTAD DE ARQUITECTURA Y DISEÑO
ESCUELA DE ARQUITECTURA

“C.E.U : CORPORACION DE EXTENSION UNIVERSITARIA”
“NUEVA VIDA UNIVERSITARIA”: AUMENTO TEMPORALIDAD EN EL CENTRO



TRIANGULO FUNDACIONAL/BORDE MICROCENTRO/SANTIAGO

PROFESORES:

VICTOR VILLALOBOS
JORGE NIETO

ALUMNO

FELIPE CRISTOBAL CAMPOSANO QUINTEROS

FECHA

27/12/2018

NOTA FINAL

5.0

ÍNDICE

INDICE	1
MARCO TEÓRICO ESPACIO INTERSTICIAL / REFERENTES	2
LA CRECIENTE DENSIFICACION URBANA EN EL CENTRO HISTORICO	3
SANTIAGO CENTRO EN CONSTANTE MUTACION	4-5
ANALISIS TRIANGULO FUNDACIONAL	6-7-8
SECCIONAL BELLAS ARTES	9
FODA	10
CASOS DE ESTUDIO	11
CORPORACION DE EXTENSION UNIVERSITARIA C.E.U	12-13
GESTION DE PROYECTO	14
ESTRATEGIA	15
IMAGEN	16
PARTIDO GENERAL	17
ISOMETRICA PARTIDO GENERAL	18
ARTEFACTO	19
DISPOSITIVOS	20 - 21
PLANTA NIVEL CALLE - CORTE 1	22
PLANTA NIVEL 10 - CORTE 2	23
PLANTA NIVEL 11 - ELEVACION	24
PLANTAS RESTANTES - ELEVACION 2	25
ISOMETRICAS PROYECTO	26 - 27
MAQUETA	28

ESPACIOS INSTERTICIALES

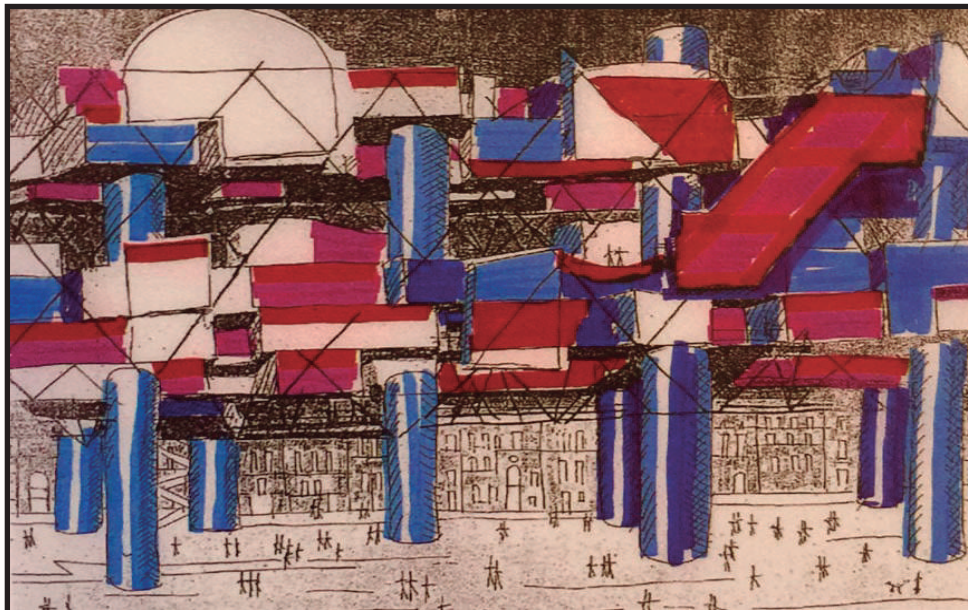

LE VILLE SPATIALE 1958 YONA FRIEDMAN

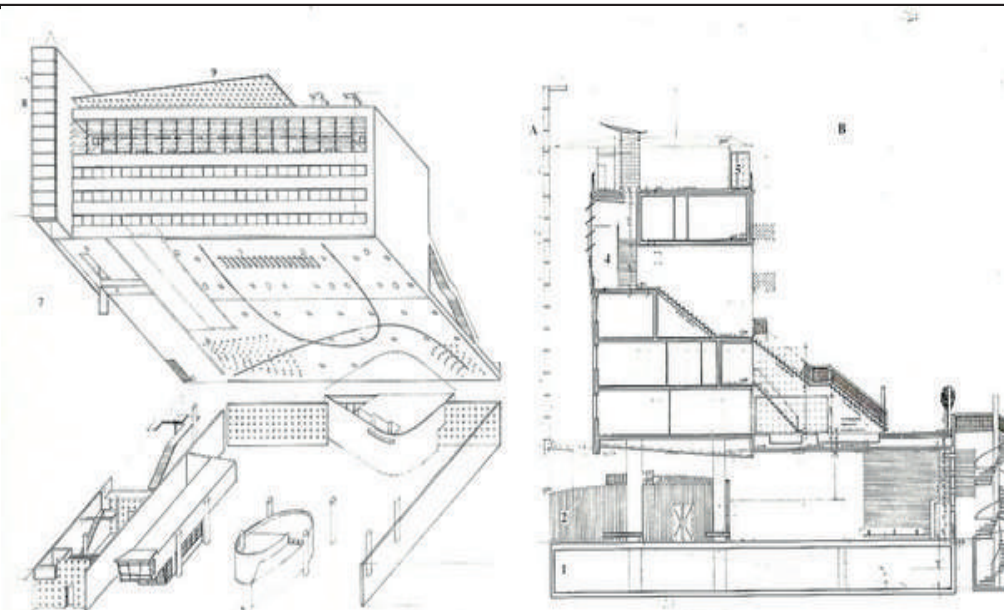

CHARLIE CHECKPOINT 1992 OMA

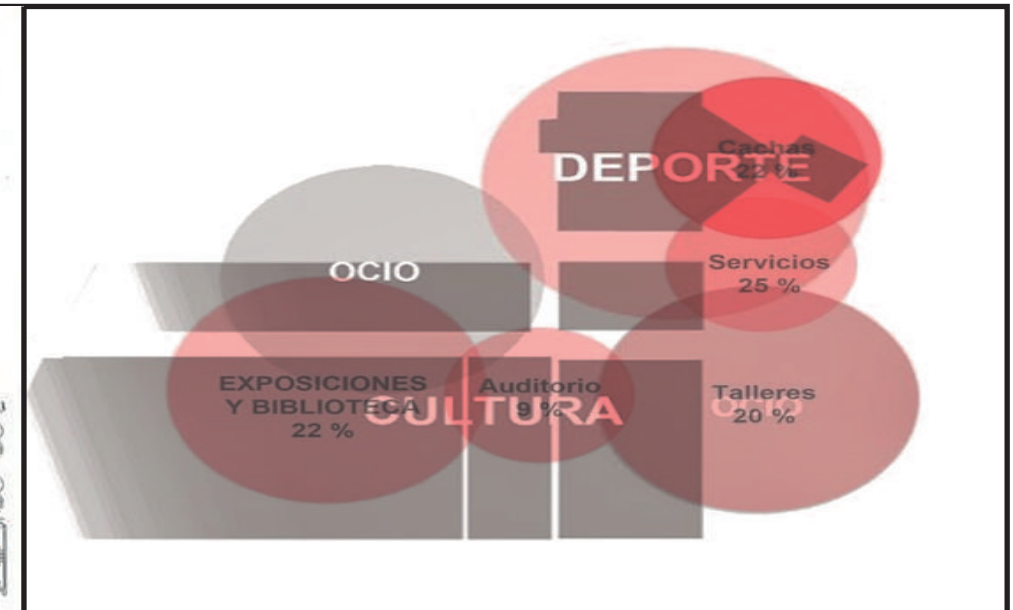

SESC POMPEIA 1977 LINA BOBARDI

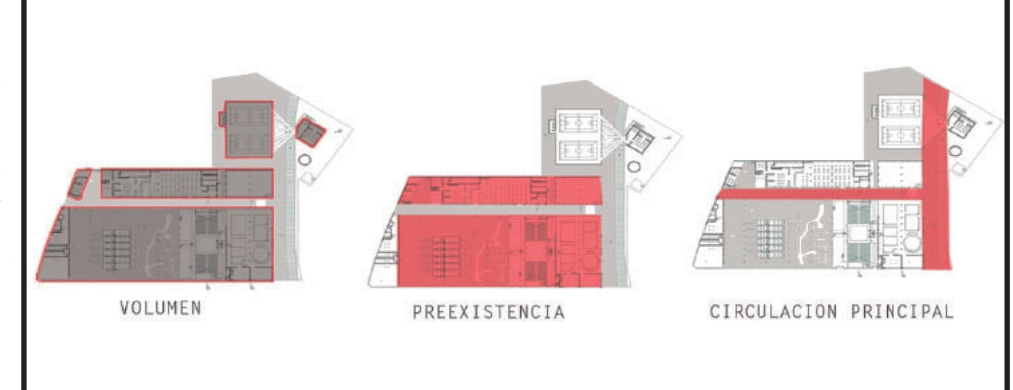
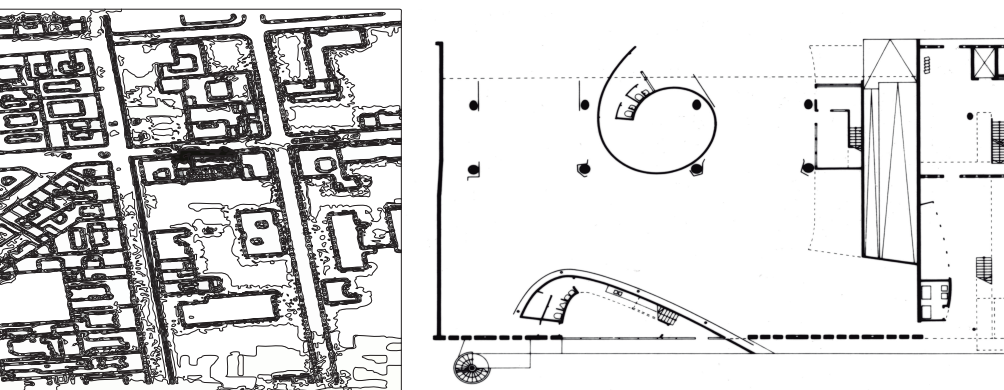
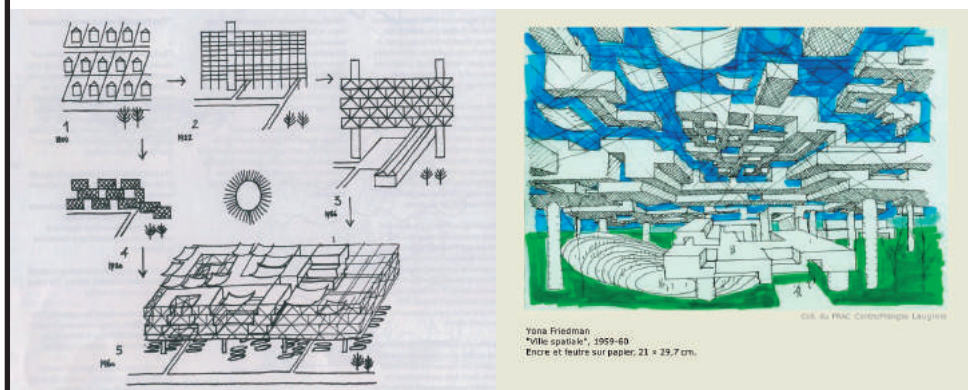

Definición:

Etimología en el latín **“interstitium”** compuesto por **“einter”** y **“sistere”**

Einter : (entre)

Sistere : (estar de pie, lugar)

Concepto: Producto de la creciente densificación urbana acelerada junto con la necesidad de edificar del mercado inmobiliario, van quedando lugares dentro de la ciudad , pero fuera de la estructura productiva de la misma , espacios inactivos u vacíos .

Estos vacíos olvidados dentro de la ciudad se definen como intersticios, siendo el primer concepto de estudio, tomándolo como un potencial lugar de desarrollo de la vida urbana del centro de Santiago.

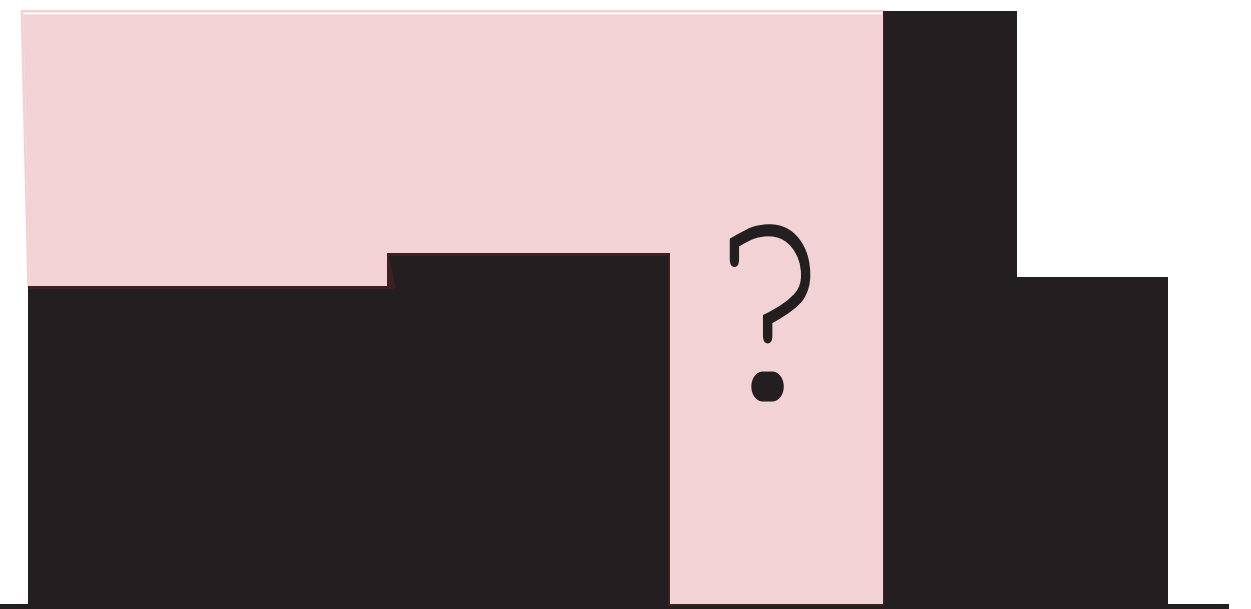

LA CRECIENTE DENSIFICACIÓN URBANA

Potencialidad de vida urbana al interior de la manzana por medio de espacios vacantes en la ciudad

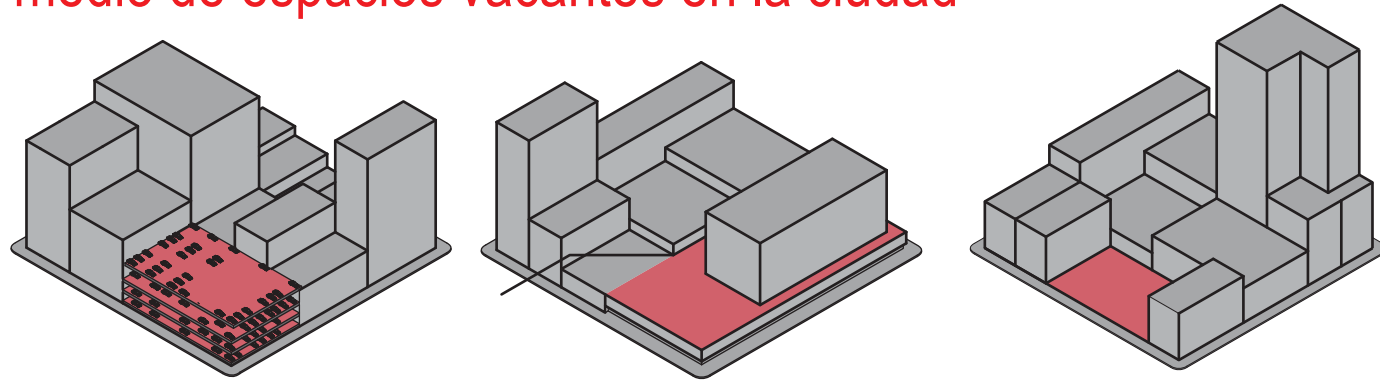

Lugares Obsoletos Espacios intersticiales Sitios Eriazos

ORGANIGRAMA ESPACIOS VACANTES

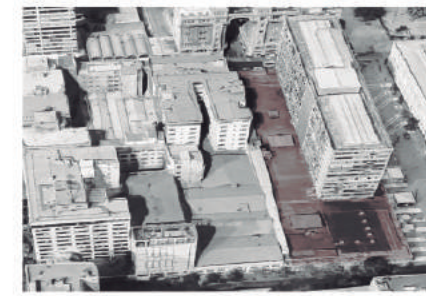
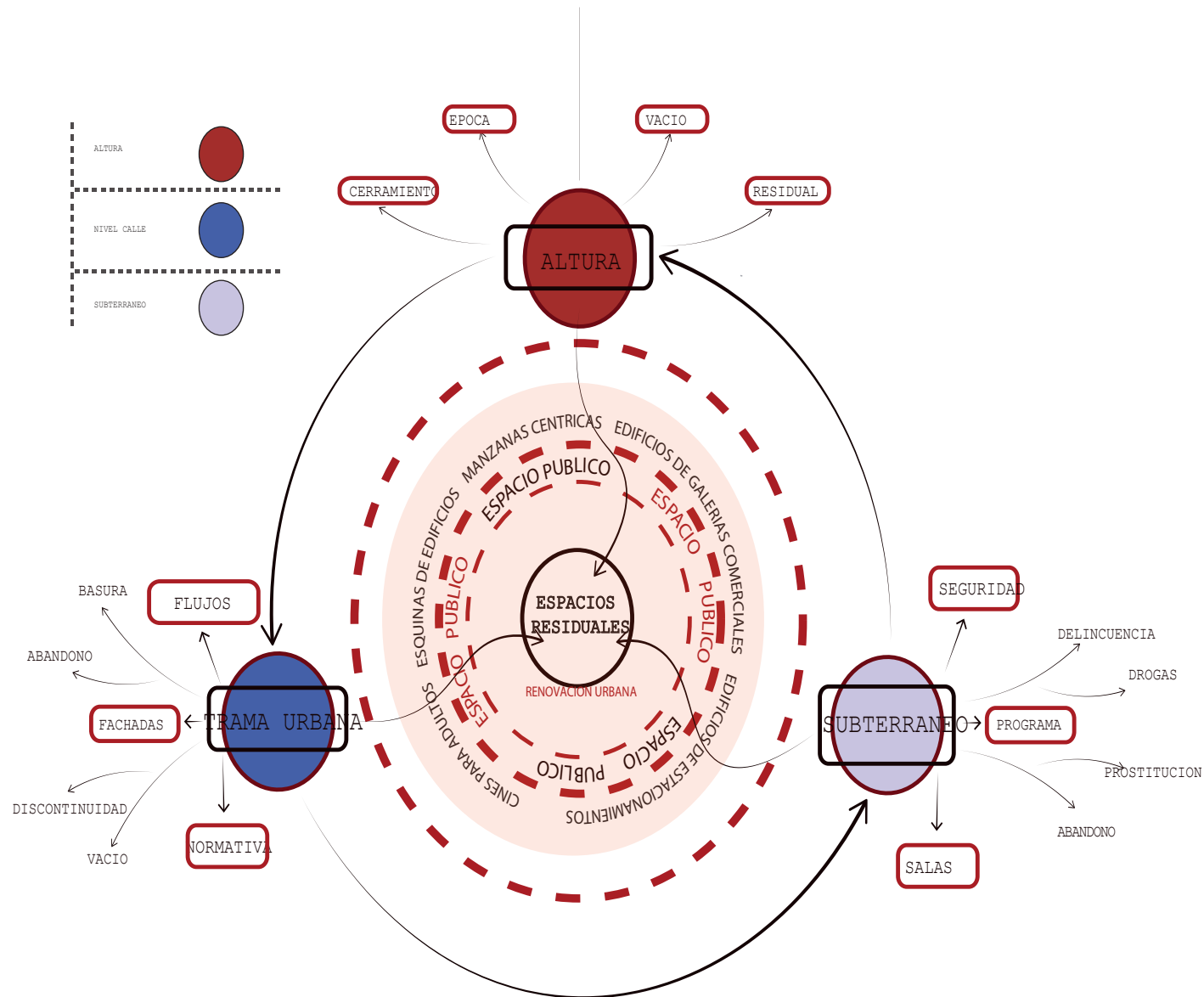

NIVEL +1



NIVEL CALLE





Poblacion Residente



Actividad Economica



Puntos Turisticos



Niveles de Servicios



Poblacion Flotante

200.000

400.000

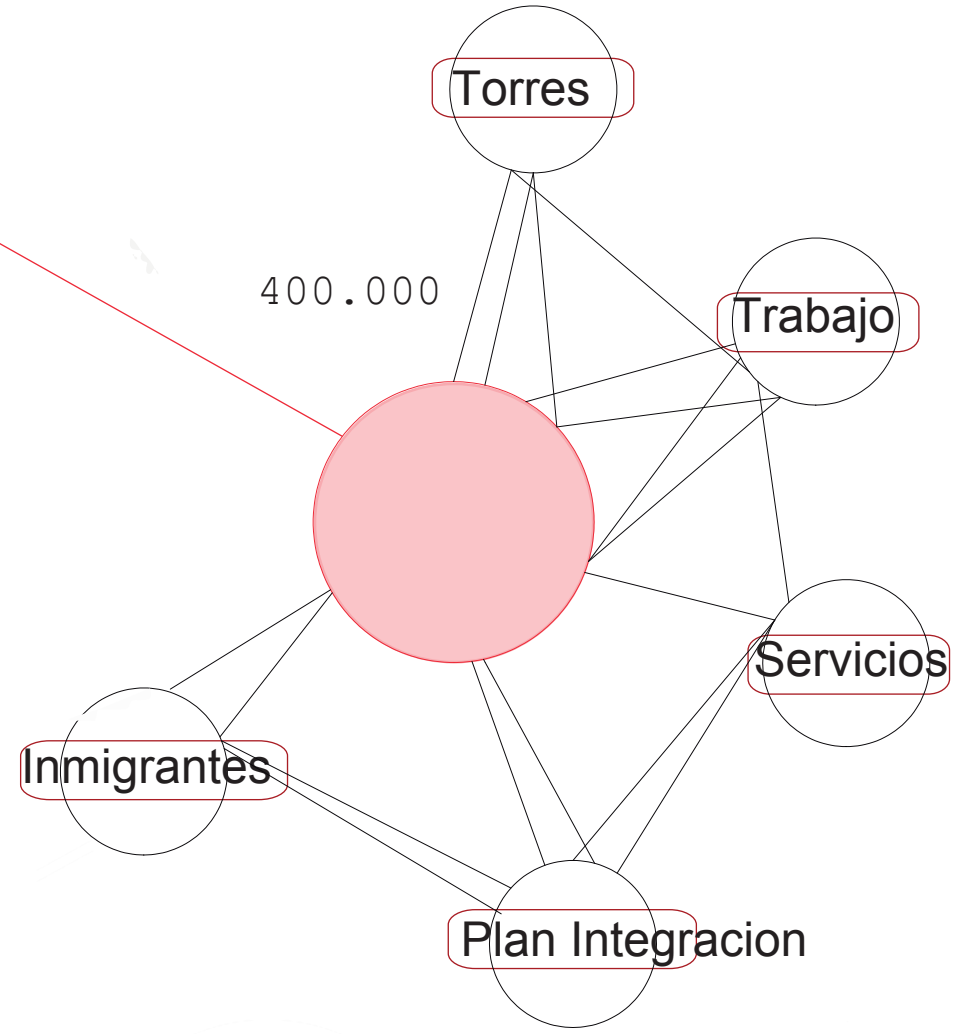

Relacion entre poblacion flotante y poblacion residente



Relacion entre poblacion flotante y Actividad economica



Relacion entre poblacion flotante y Niveles de servicio





TRAMA MULTIDISCIPLINAR

La ciudad en constante mutación

A través de los años el triangulo fundacional ah sufrido diversos cambios debido a los procesos de modernización, al ser un punto donde se concentran las actividades tiene un alto nivel de deterioro.

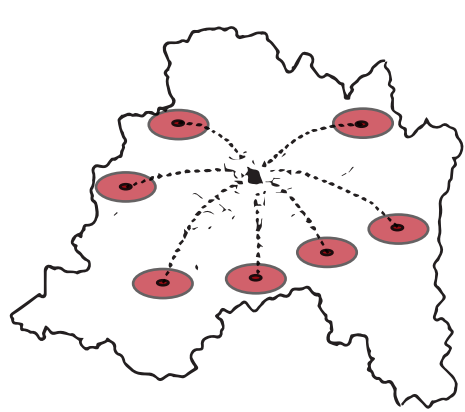

Dependencia del centro



Punto de alta conectividad

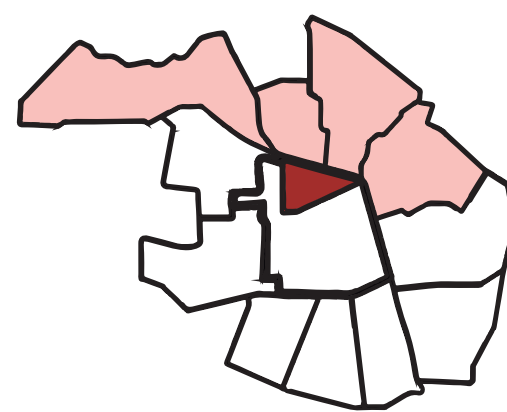

Poblacion flotante muy alta

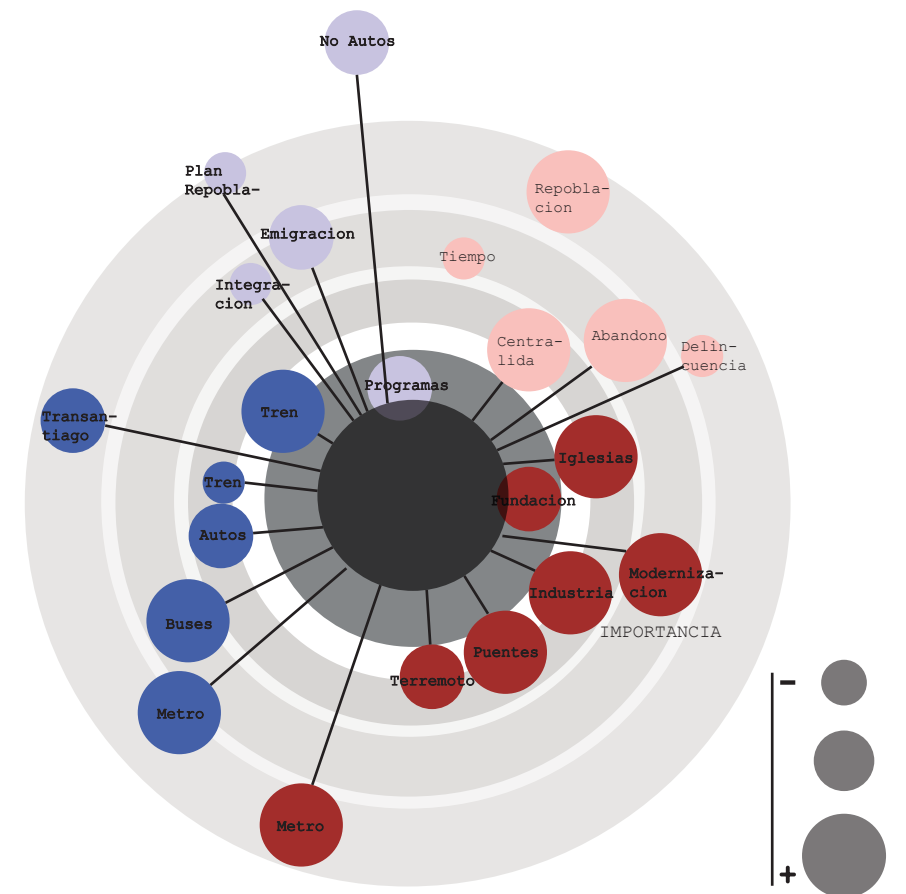

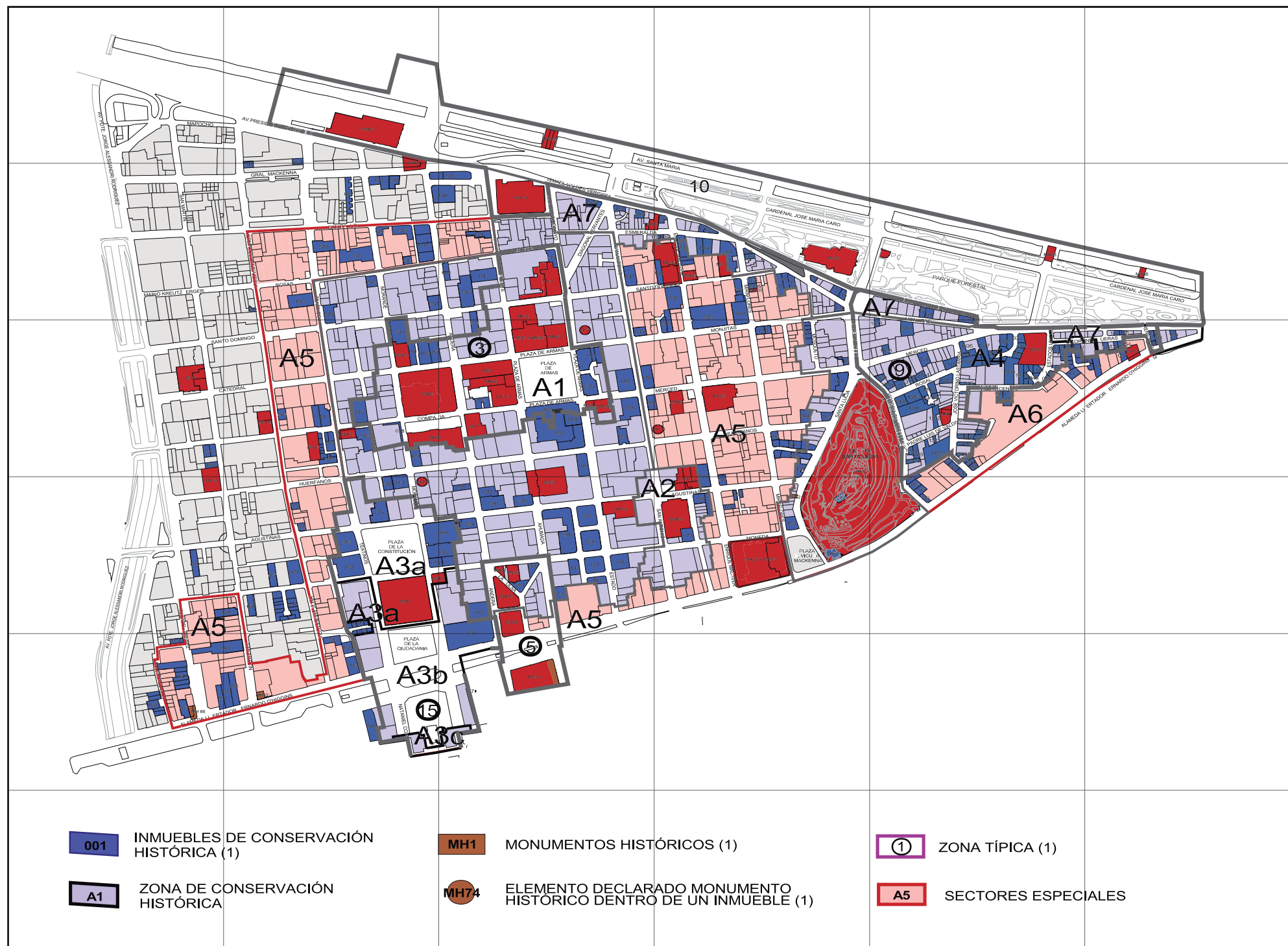

Barrios

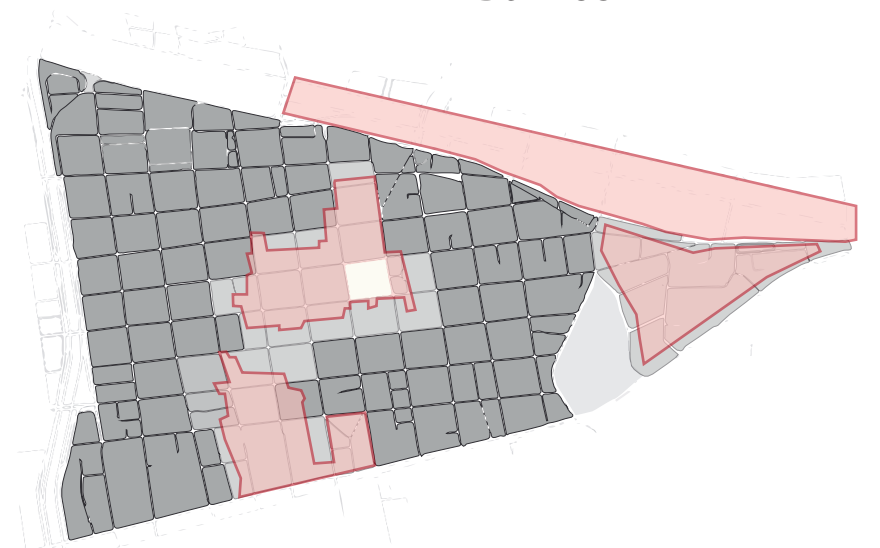

Edificios Patrimoniales

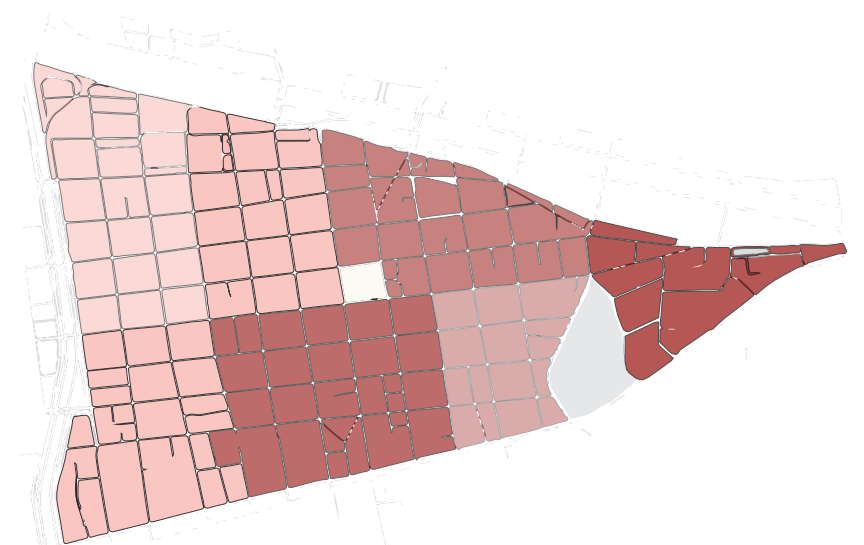

Mal Estado

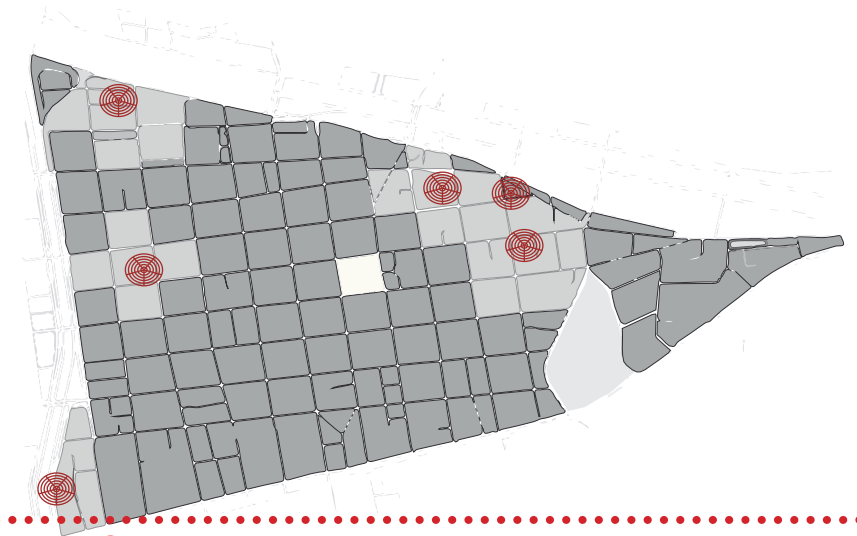

PLAN REGULADOR

la zona presenta las concentraciones de construcciones protegidas que se encuentran en mal estado debido a que es una zona de Barrio bellas artes mas descuidada del triangulo

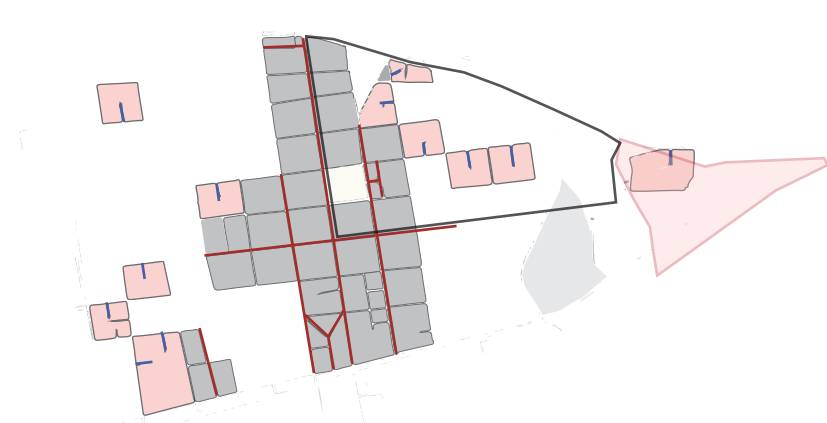
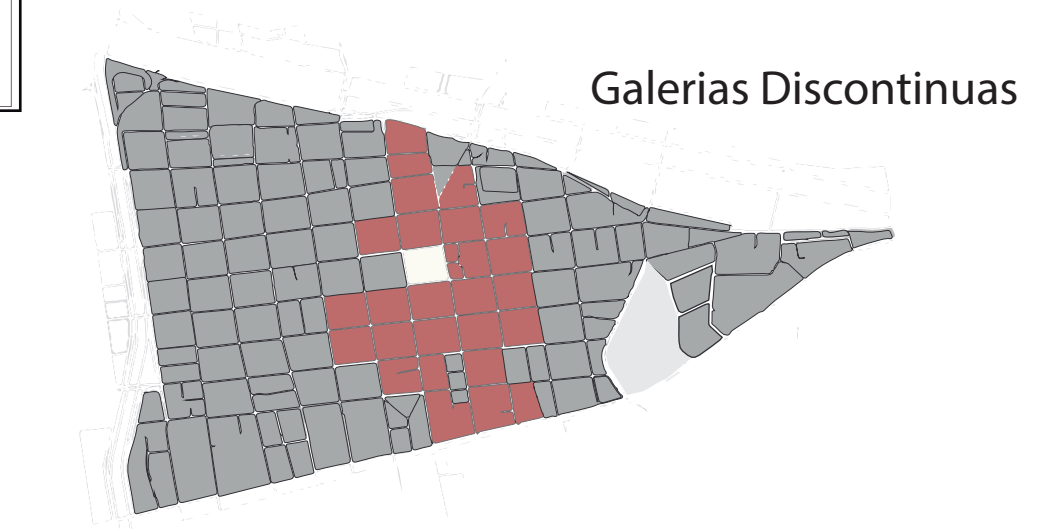
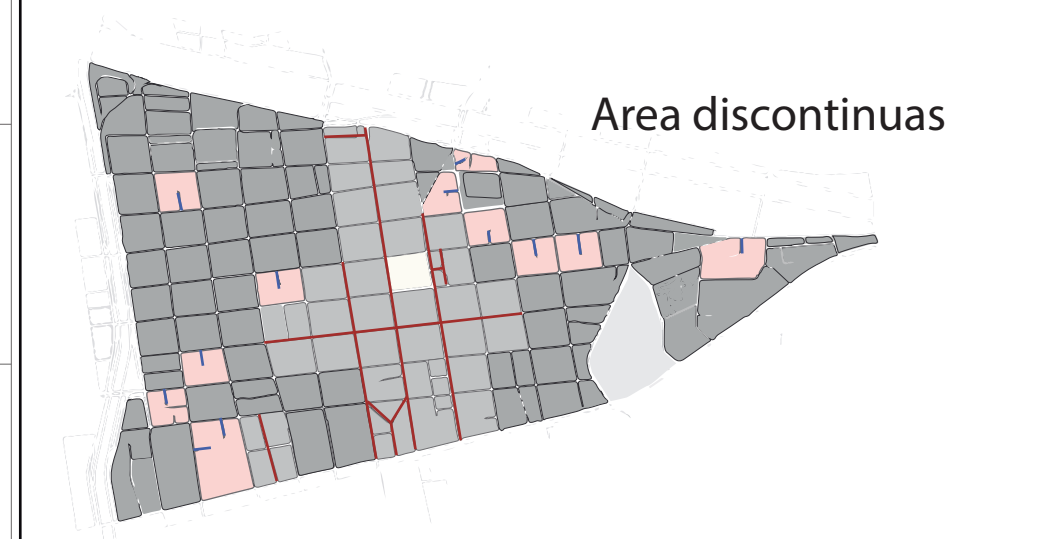
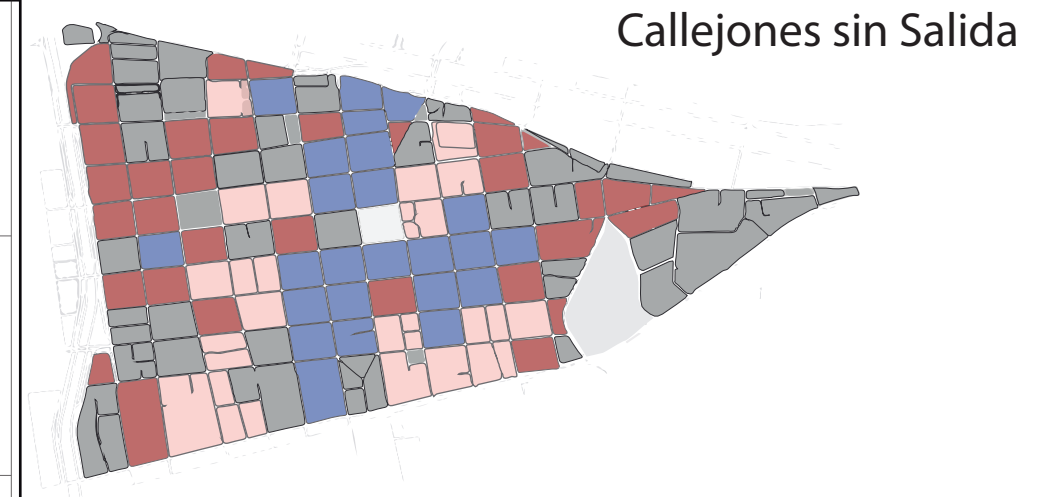

CONECTIVIDAD

El sistema de galerías que rodea el punto neurálgico de Santiago se ve interrumpido por la cantidad de desconexión de las manzanas que se observan en el Barrio Bellas Artes.



Nivel Calle

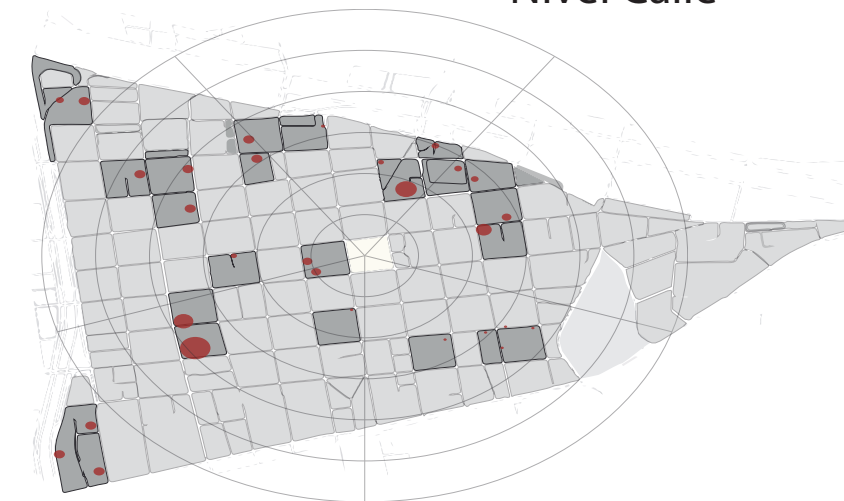

Nivel Superior

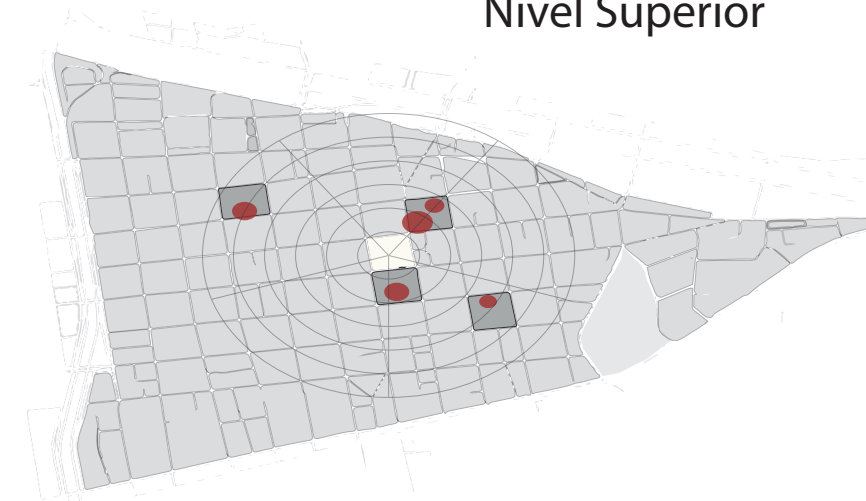

Nivel Subterráneo

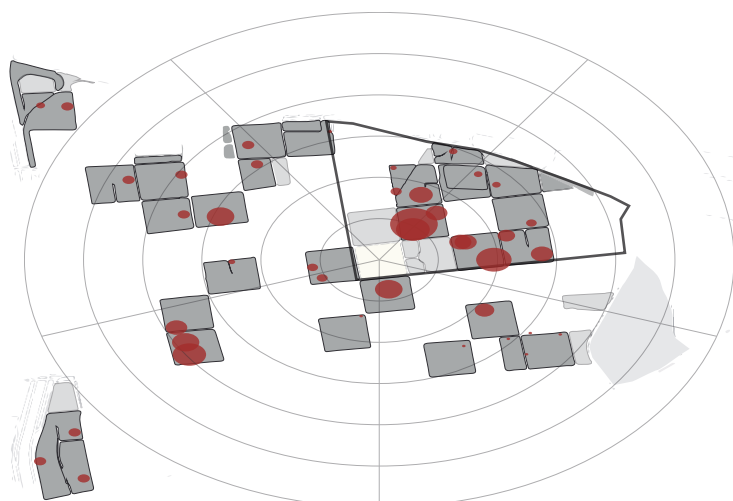
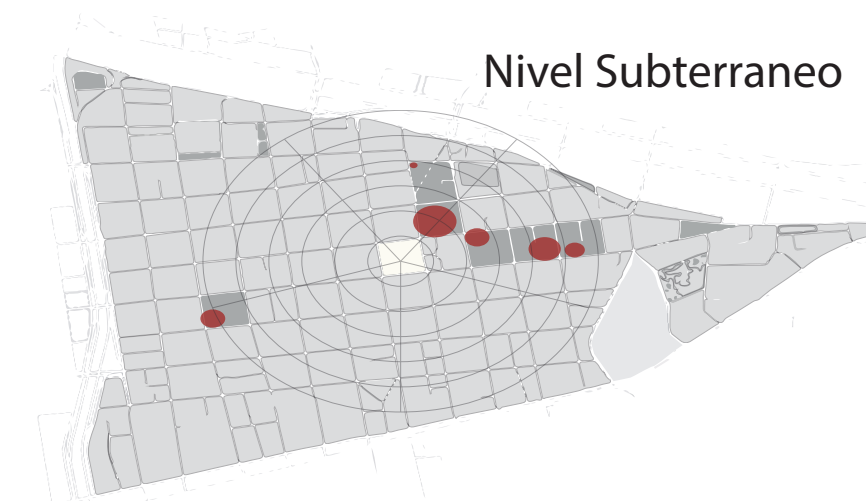

ESPACIOS INSTERTICIALES

Se presentan espacios residuales en diferentes estratos los cuales los cuales presentan su mayor área en el sector del Barrio Bellas Artes

SECCIONAL BARRIO BELLAS ARTES

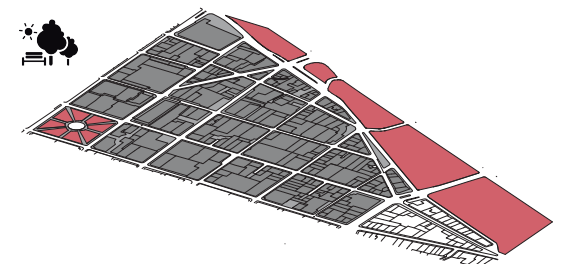
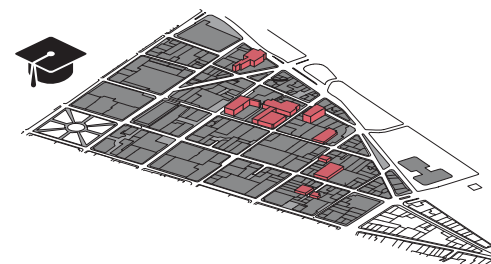
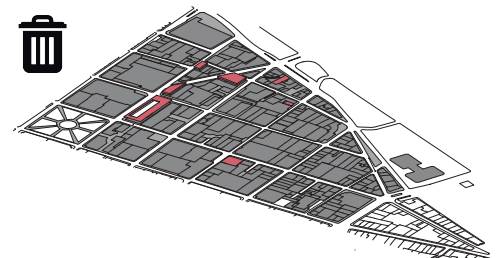
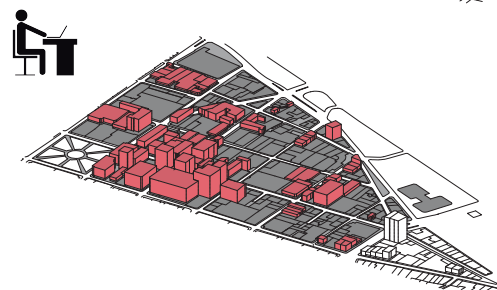
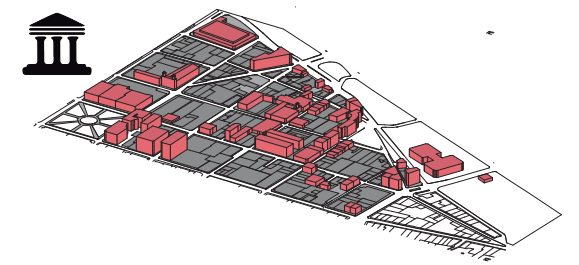
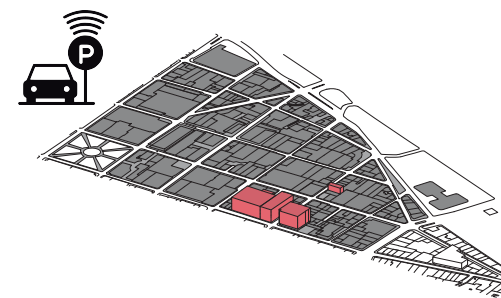
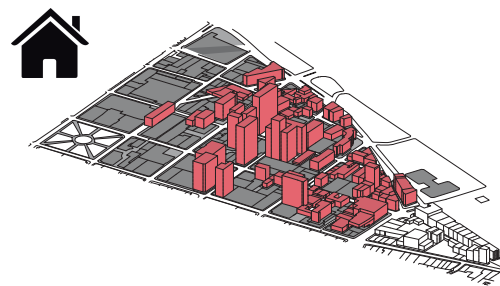
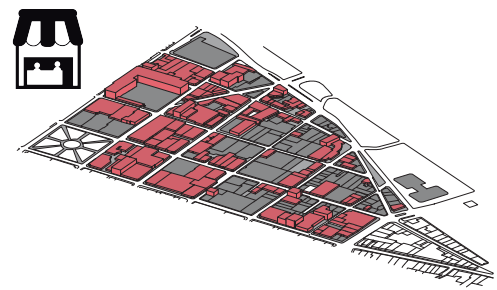
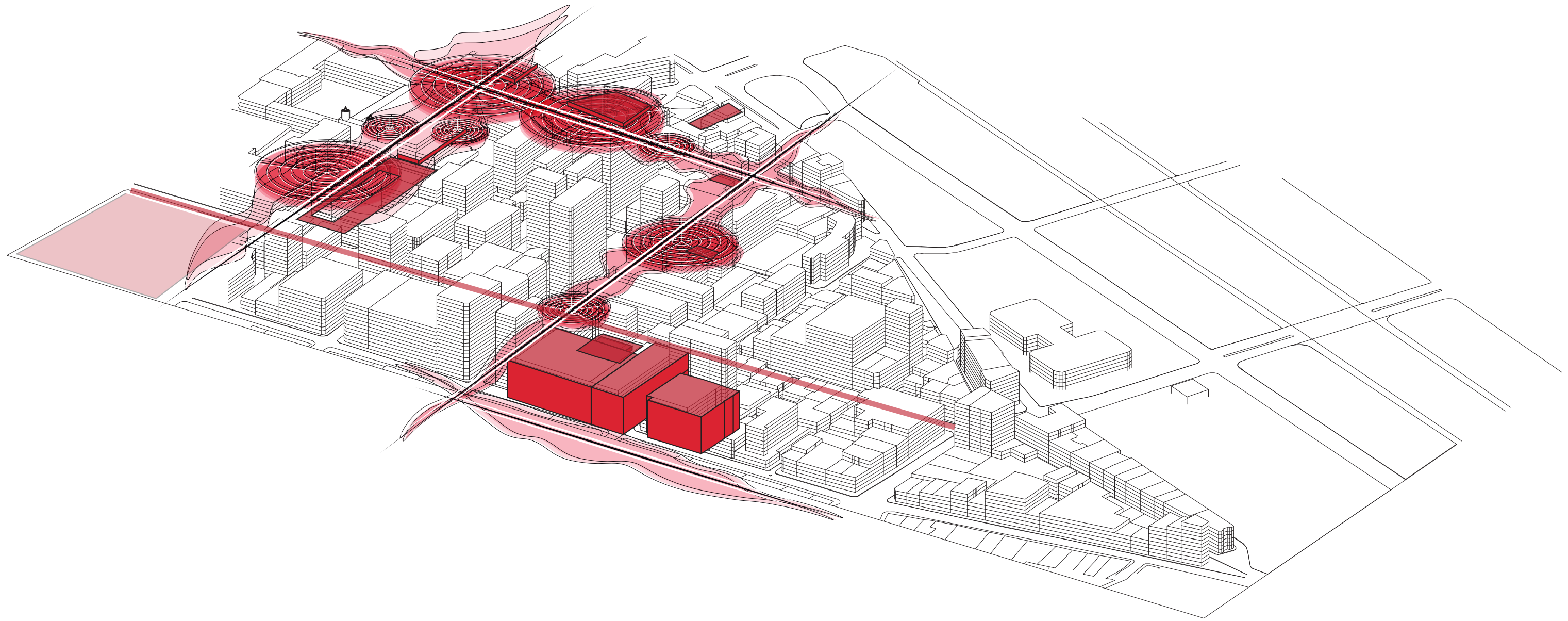

Oficinas

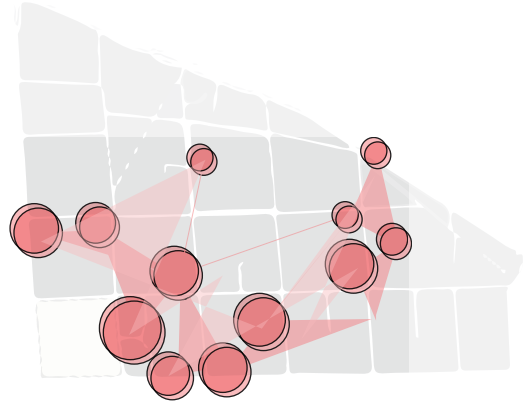

Espacios Instersticiales

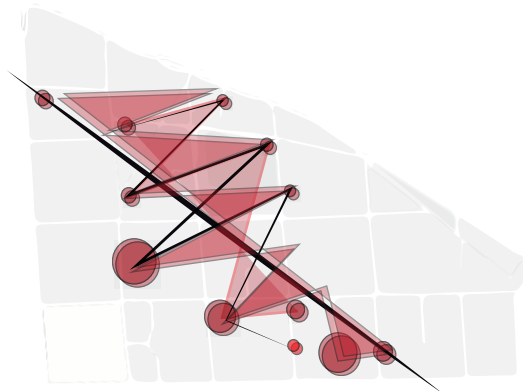

Comercio

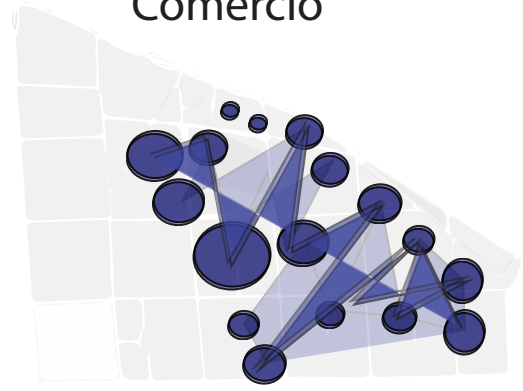

Educacion superior

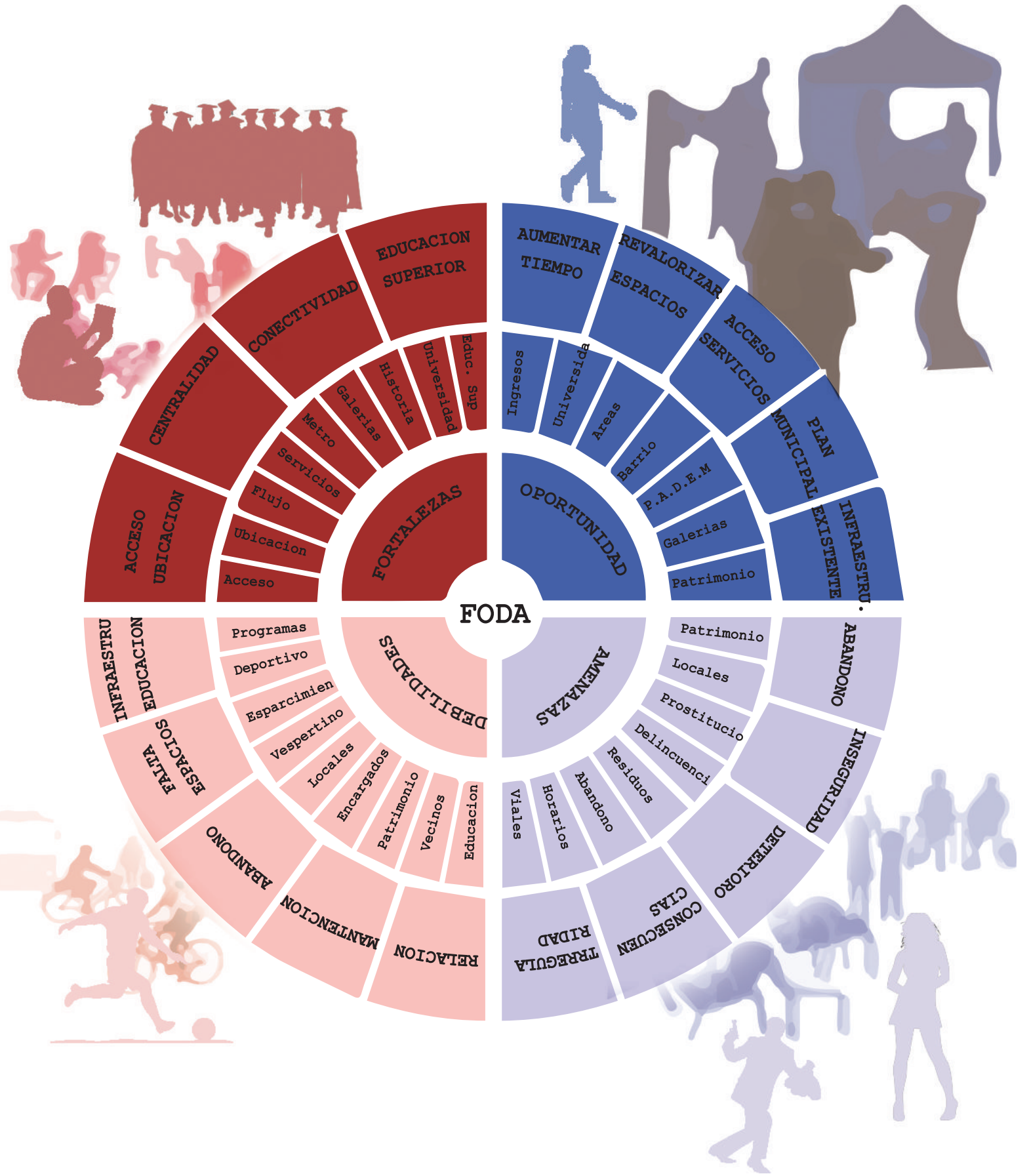
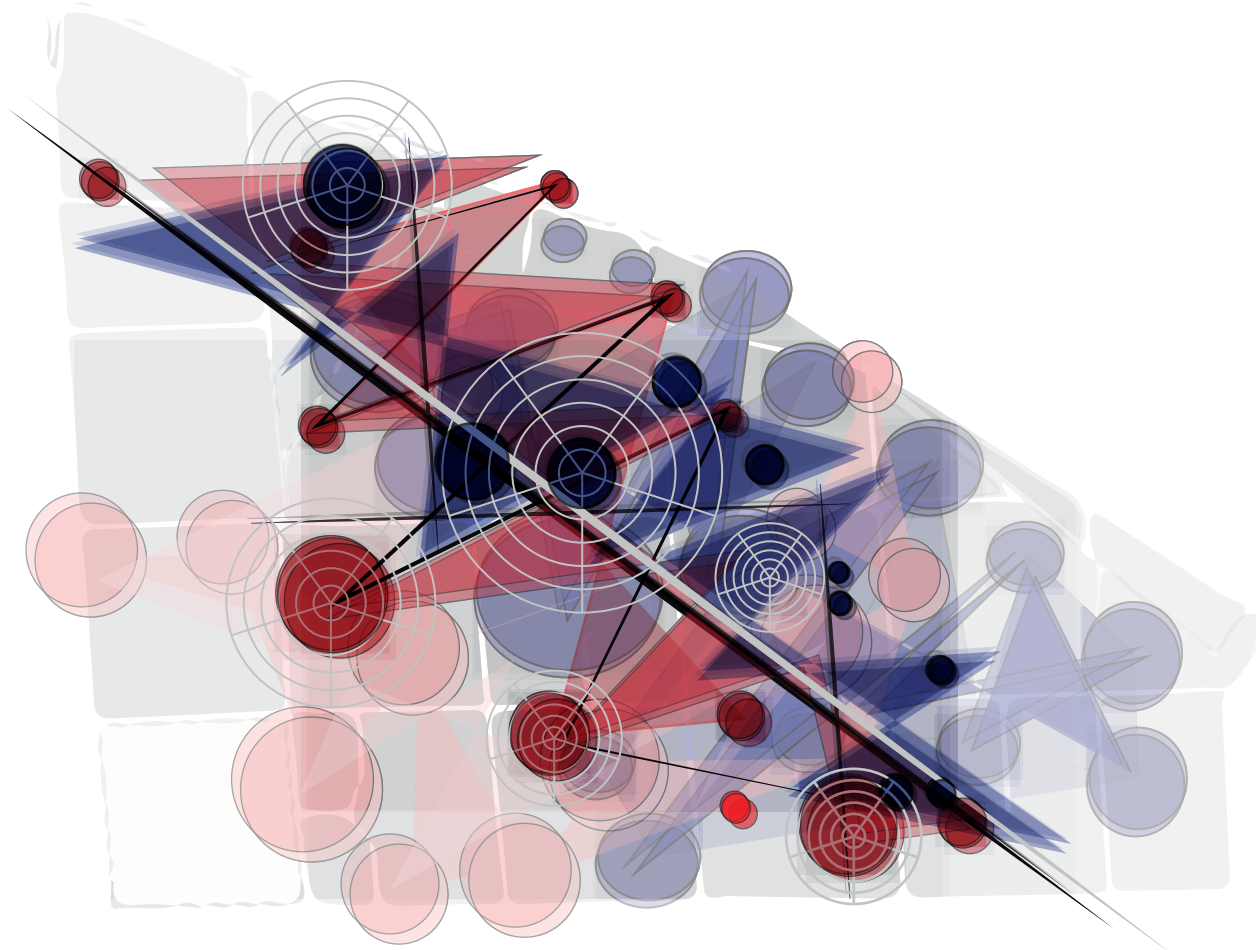

FORTALEZAS

OPORTUNIDAD

DEBILIDADES

AMENAZAS

FODA



Monjitas / Mac-iver

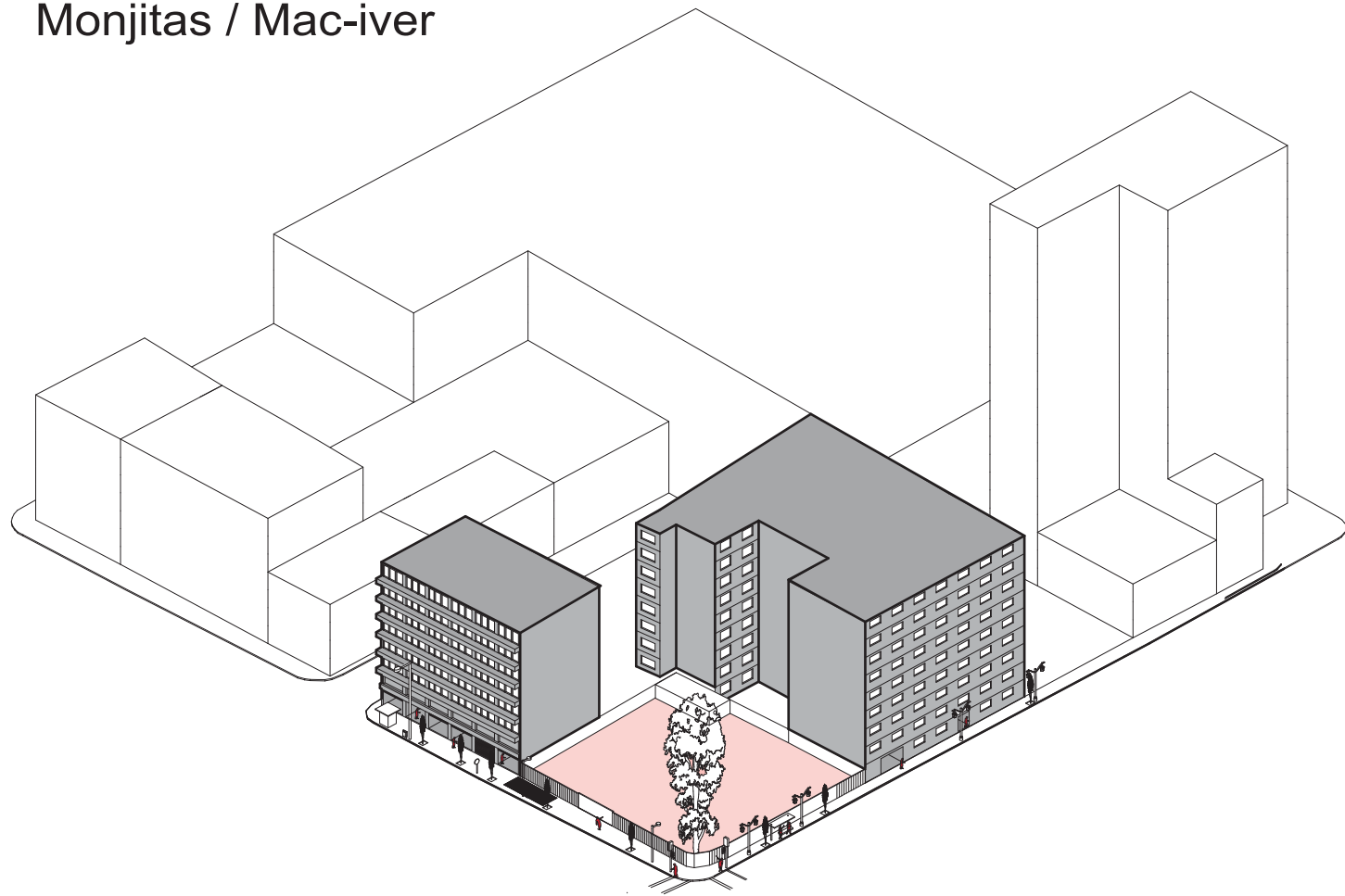

Merced / Miraflores

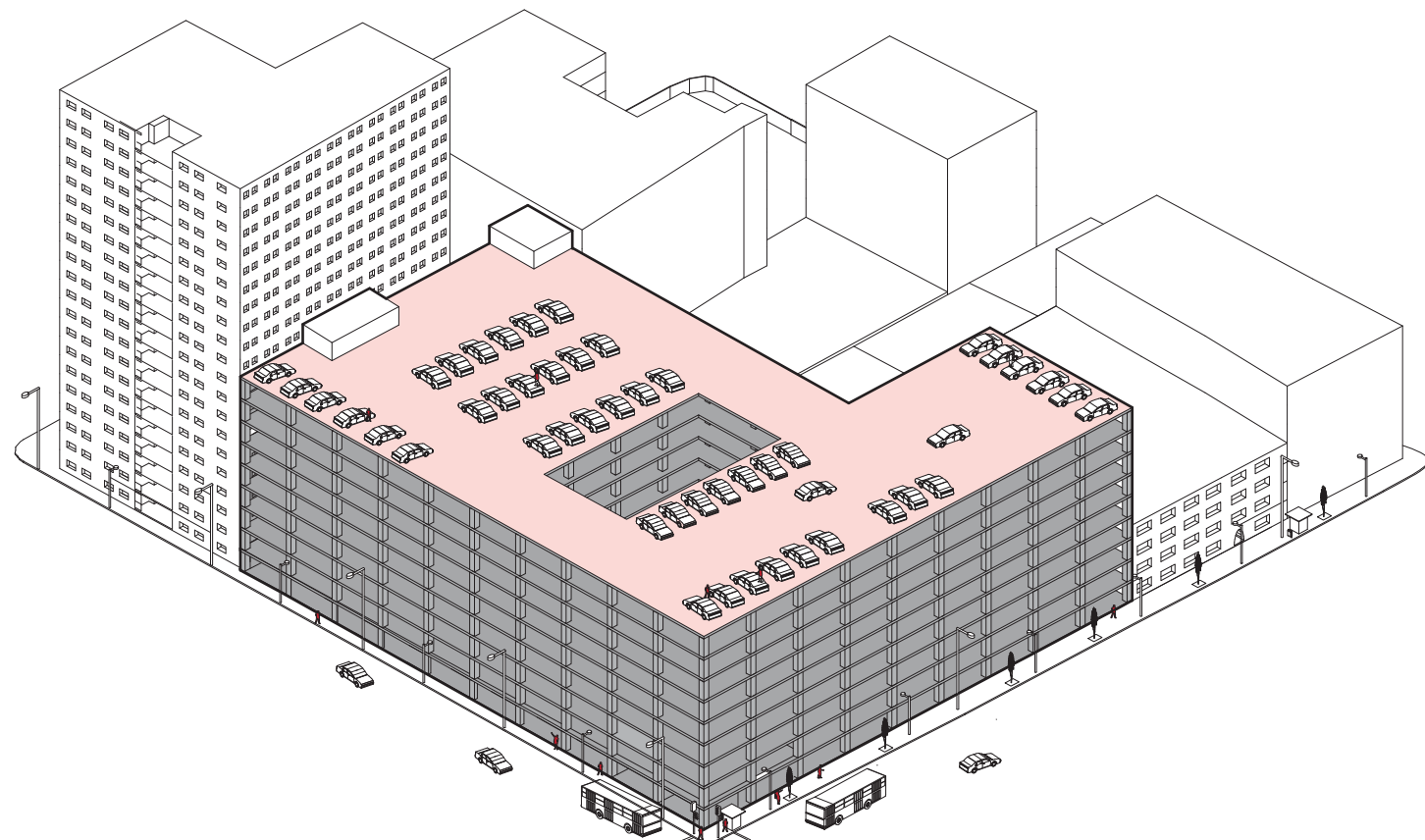

Monjitas / 21 de Mayo

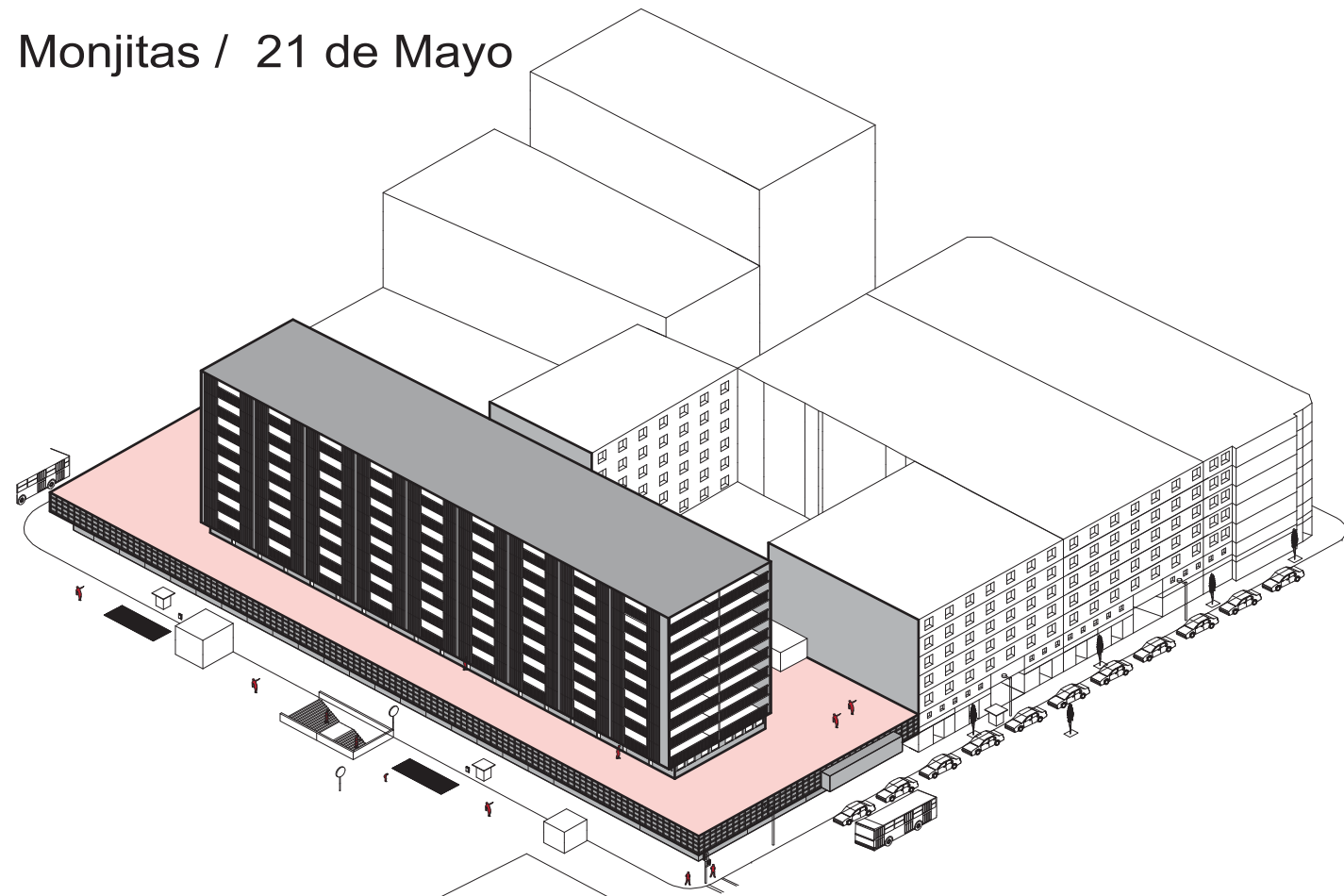

Monjitas

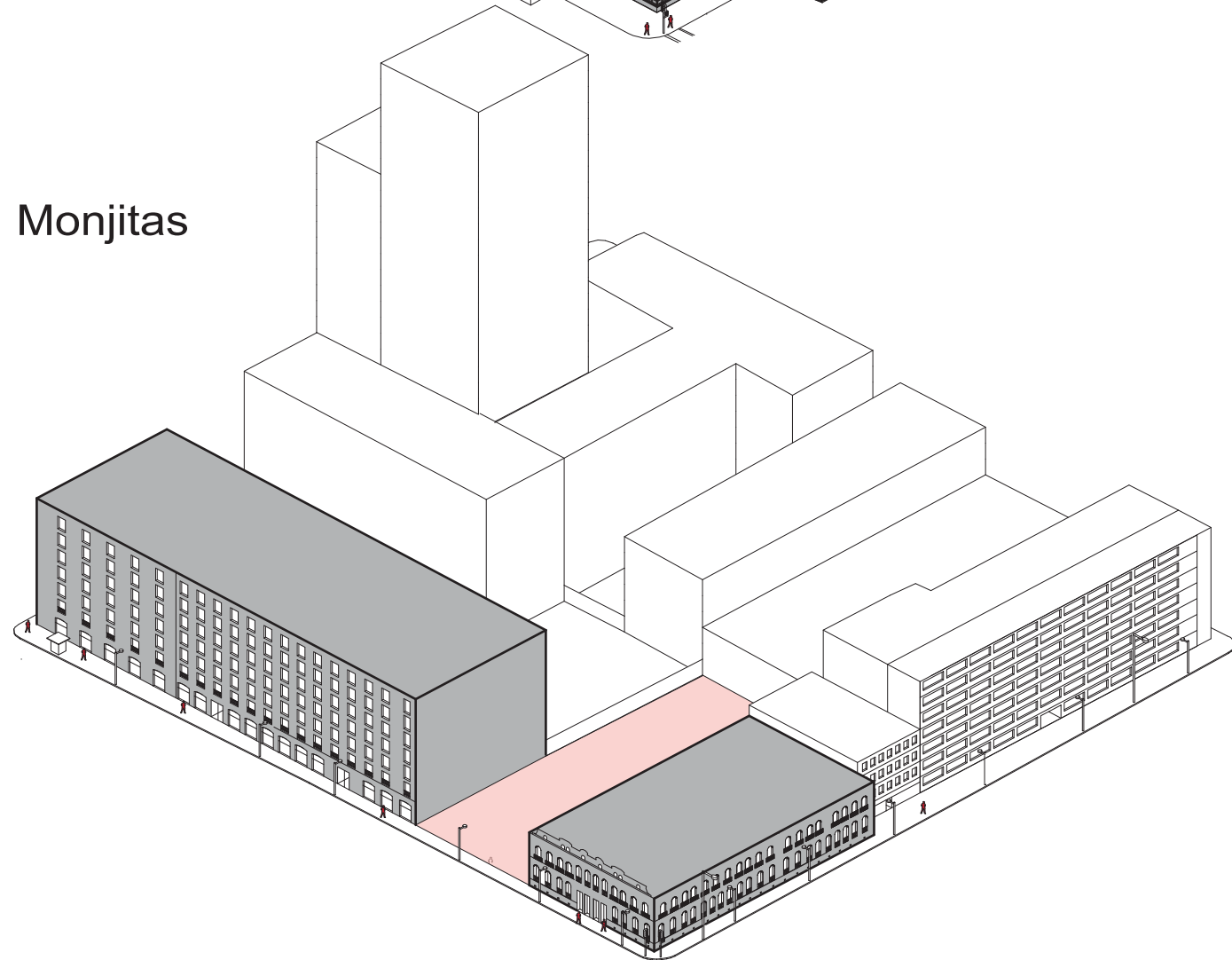

“CORPORACION DE EXTENSION UNIVERSITARIA”

Nuevo espíritu Universitario

El centro histórico de Santiago se enfrenta constantemente a las consecuencias de la modernización las cuales presentan un desarrollo rápido, lo que implicando un deterioro constante en los tejidos tradicionales .

Si el C.E.U es capaz de integrar programas que tengan relación con las universidades y estudios superiores yo podría aumentar el horario del sector Barrio Bellas Artes en Santiago centro.

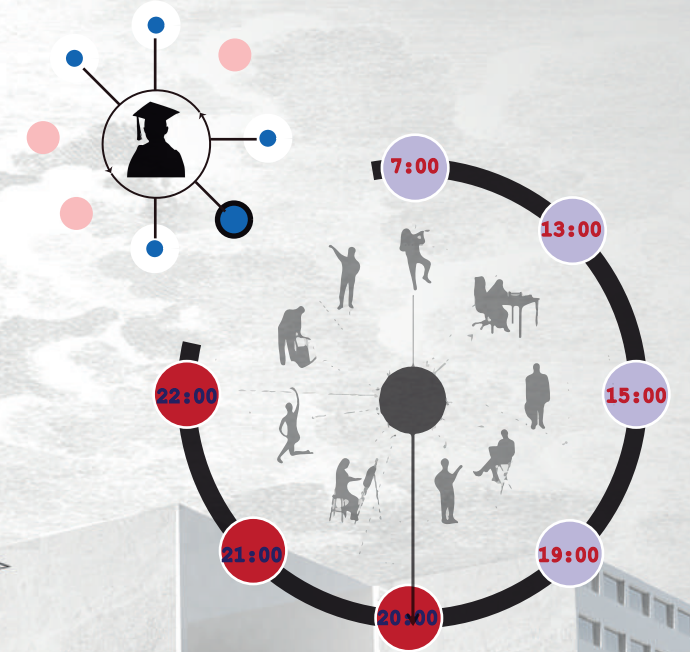



PROGRAMAS ENCUESTADOS				
Servicios				
Deportivos				
Talleres vesp.				
Salas de estudio				
Auditorios				
Espectaculo				
Viv. Estudiantes				
Comedores				
Areas Colectivas				
Exposicion				
Biblioteca				



PROGRAMAS ENCUESTADOS				
Servicios				
Deportivos				
Talleres vesp.				
Salas de estudio				
Auditorios				
Espectaculo				
Viv. Estudiantes				
Comedores				
Areas Colectivas				
Libreria				
Biblioteca				



PROGRAMAS ENCUESTADOS				
Servicios				
Deportivos				
Talleres vesp.				
Salas de estudio				
Auditorios				
Espectaculo				
Viv. Estudiantes				
Comedores				
Areas Colectivas				
Exposicion				
Biblioteca				



PROGRAMAS ENCUESTADOS				
Servicios				
Deportivos				
Talleres vesp.				
Salas de estudio				
Auditorios				
Espectaculo				
Viv. Estudiantes				
Comedores				
Areas Colectivas				
Exposicion				
Biblioteca				



PROGRAMAS ENCUESTADOS				
Servicios				
Deportivos				
Talleres vesp.				
Salas de estudio				
Auditorios				
Espectaculo				
Viv. Estudiantes				
Comedores				
Areas Colectivas				
Exposicion				
Biblioteca				



PROGRAMAS ENCUESTADOS				
Servicios				
Deportivos				
Talleres vesp.				
Salas de estudio				
Auditorios				
Espectaculo				
Viv. Estudiantes				
Comedores				
Areas Colectivas				
Exposicion				
Biblioteca				



PROGRAMAS ENCUESTADOS				
Servicios				
Deportivos				
Talleres vesp.				
Salas de estudio				
Auditorios				
Espectaculo				
Viv. Estudiantes				
Comedores				
Areas Colectivas				
Exposicion				
Biblioteca				



PROGRAMAS ENCUESTADOS				
Servicios				
Deportivos				
Talleres vesp.				
Salas de estudio				
Auditorios				
Espectaculo				
Viv. Estudiantes				
Comedores				
Areas Colectivas				
Exposicion				
Biblioteca				

Agentes Participantes

BUS

BARRIO UNIVERSITARIO SANTIAGO

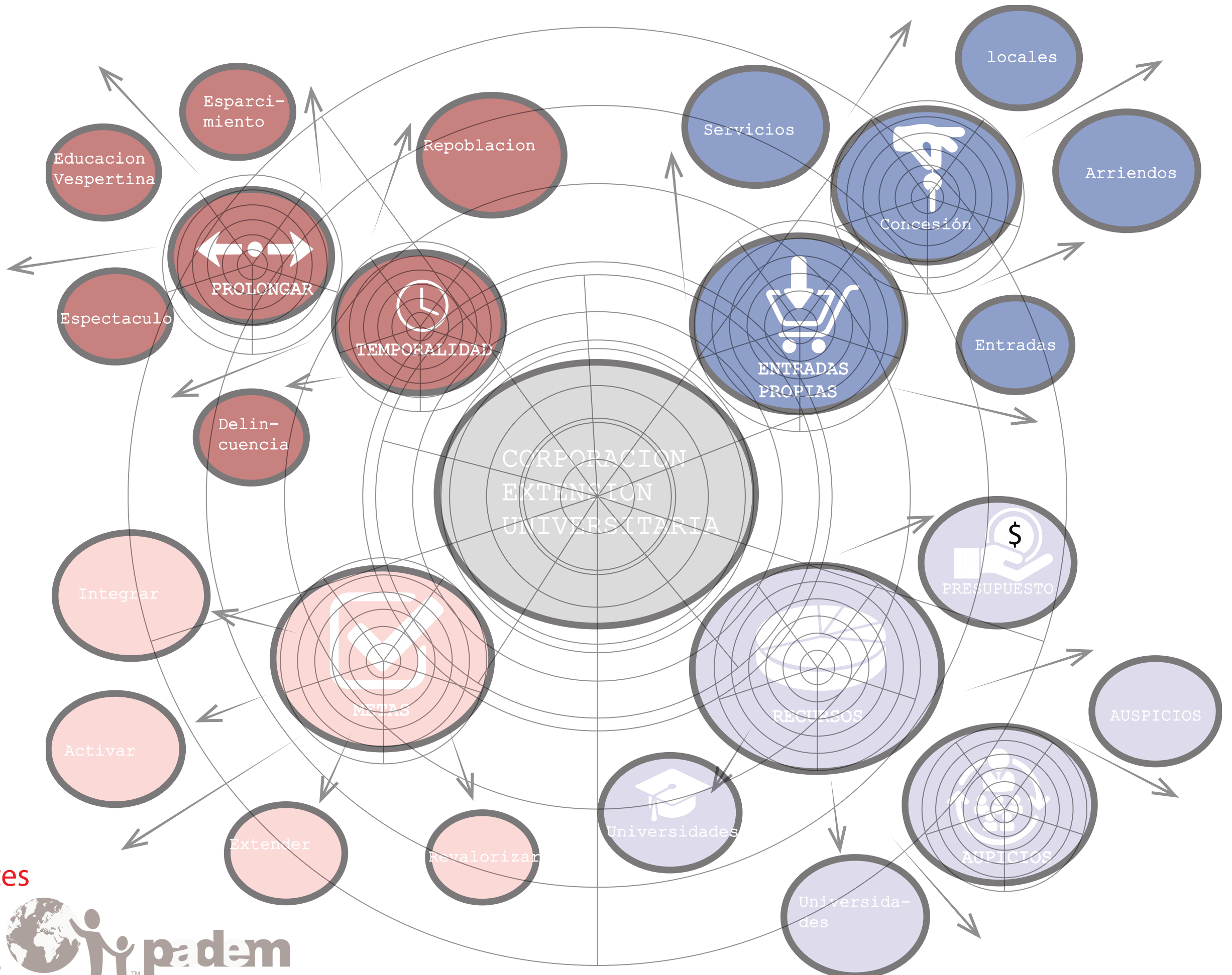

LA CIUDAD COMO UN HIBRIDO

Valoración de los sitios vacantes

A través de los años el triangulo fundacional ah sufrido diversos cambios debido a los procesos de modernización, al ser un punto donde se concentran las actividades tiene un alto nivel de deterioro.

Detectar

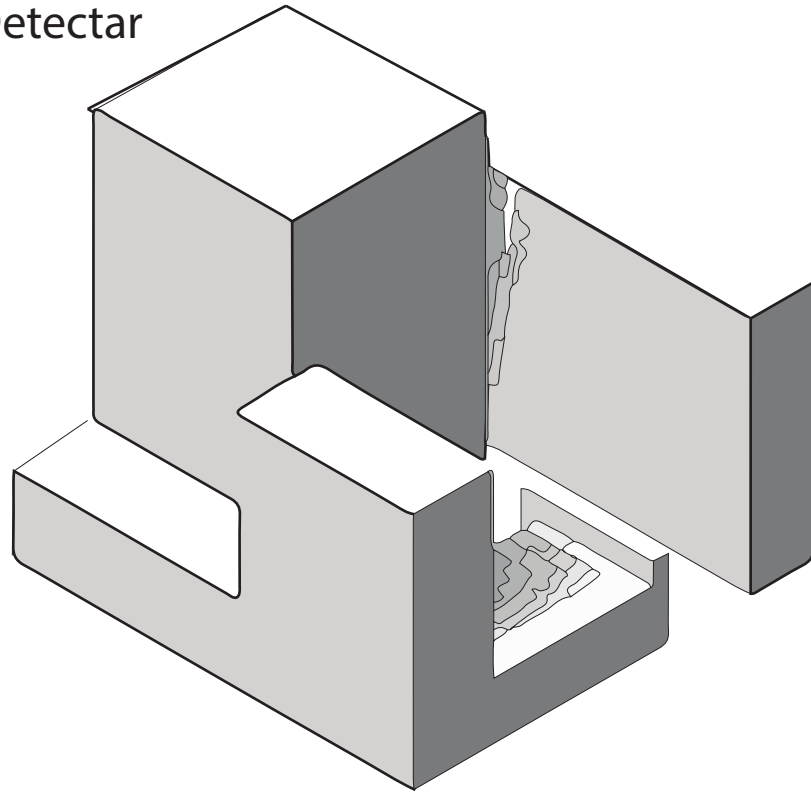

Clasificar

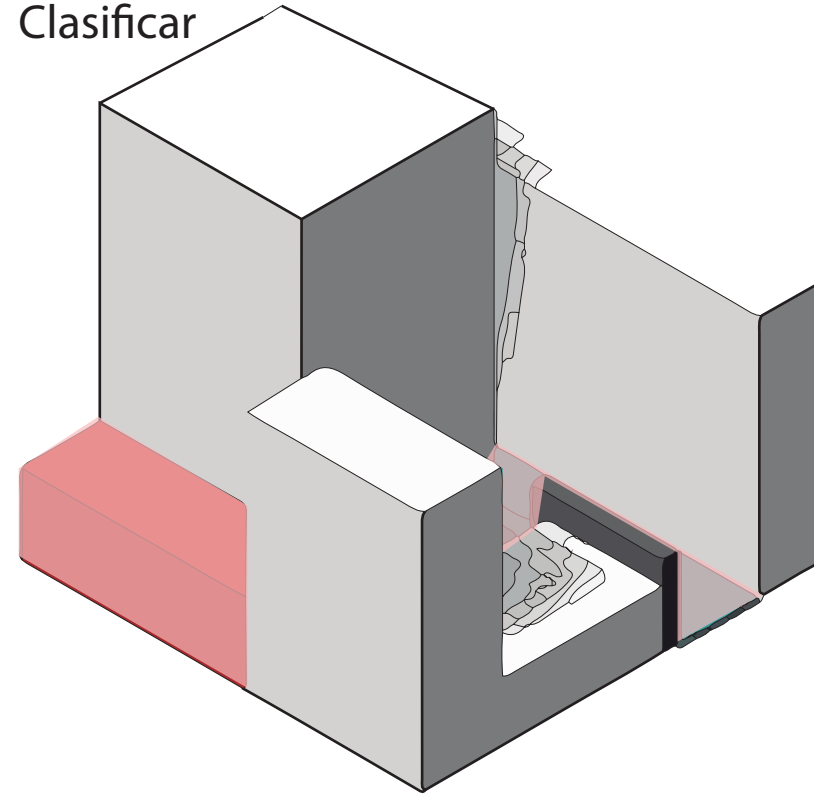

Completar

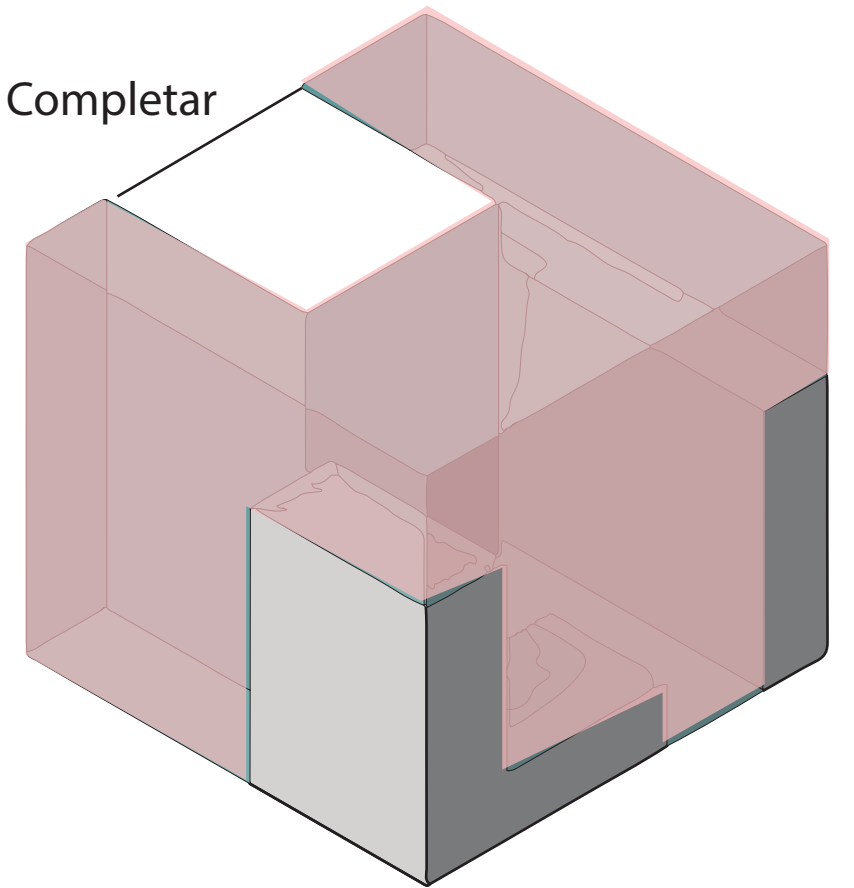

Detectar

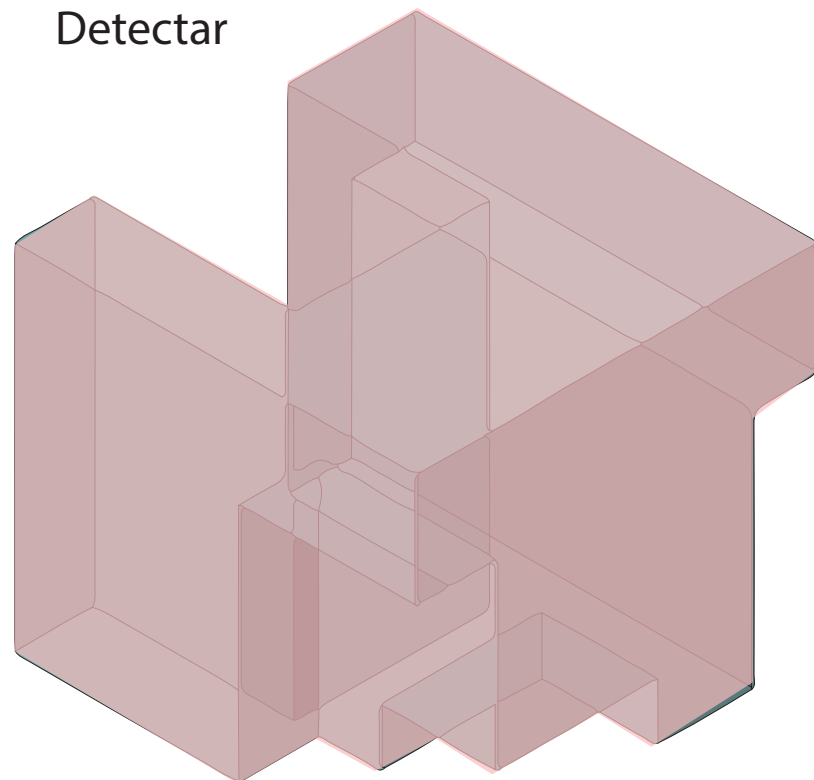

Estructurar

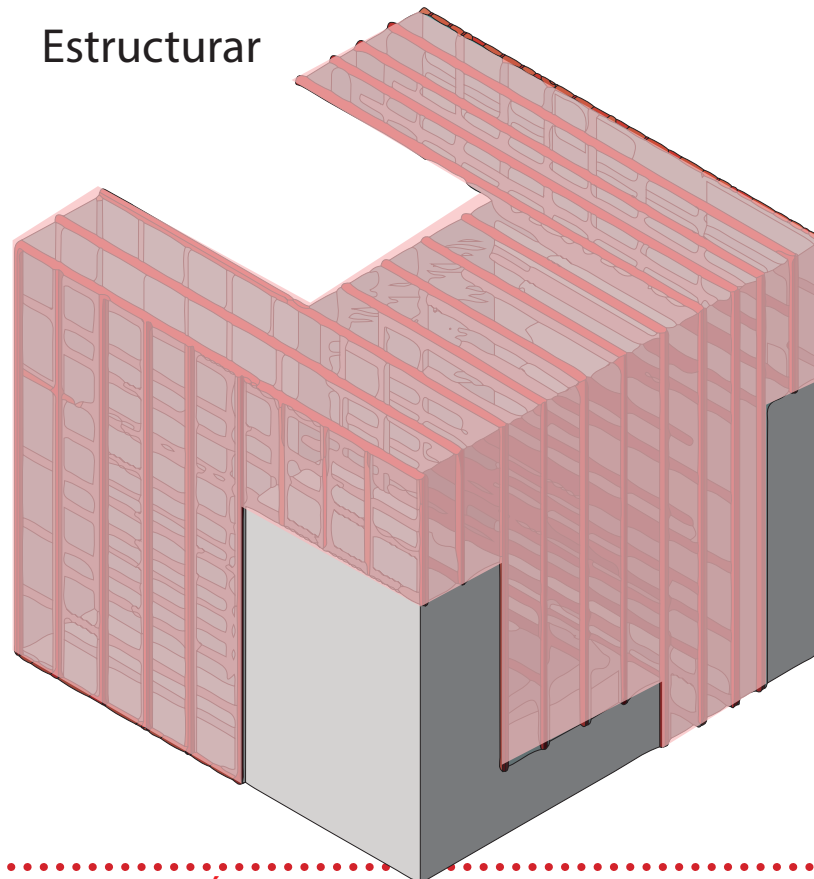

Cualificar

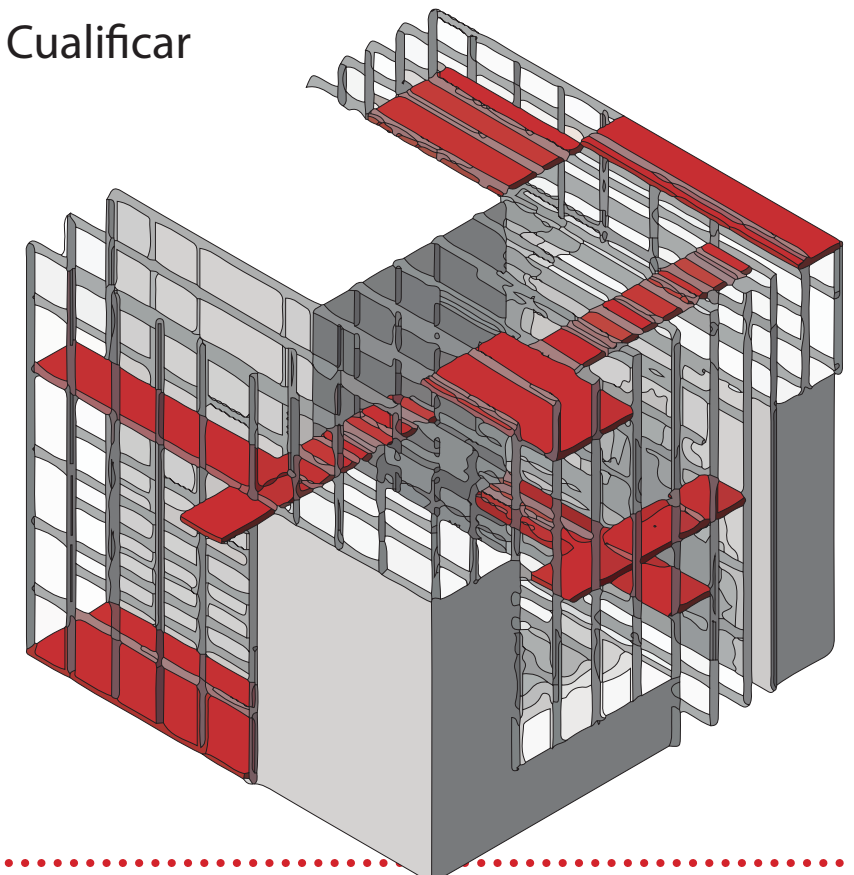

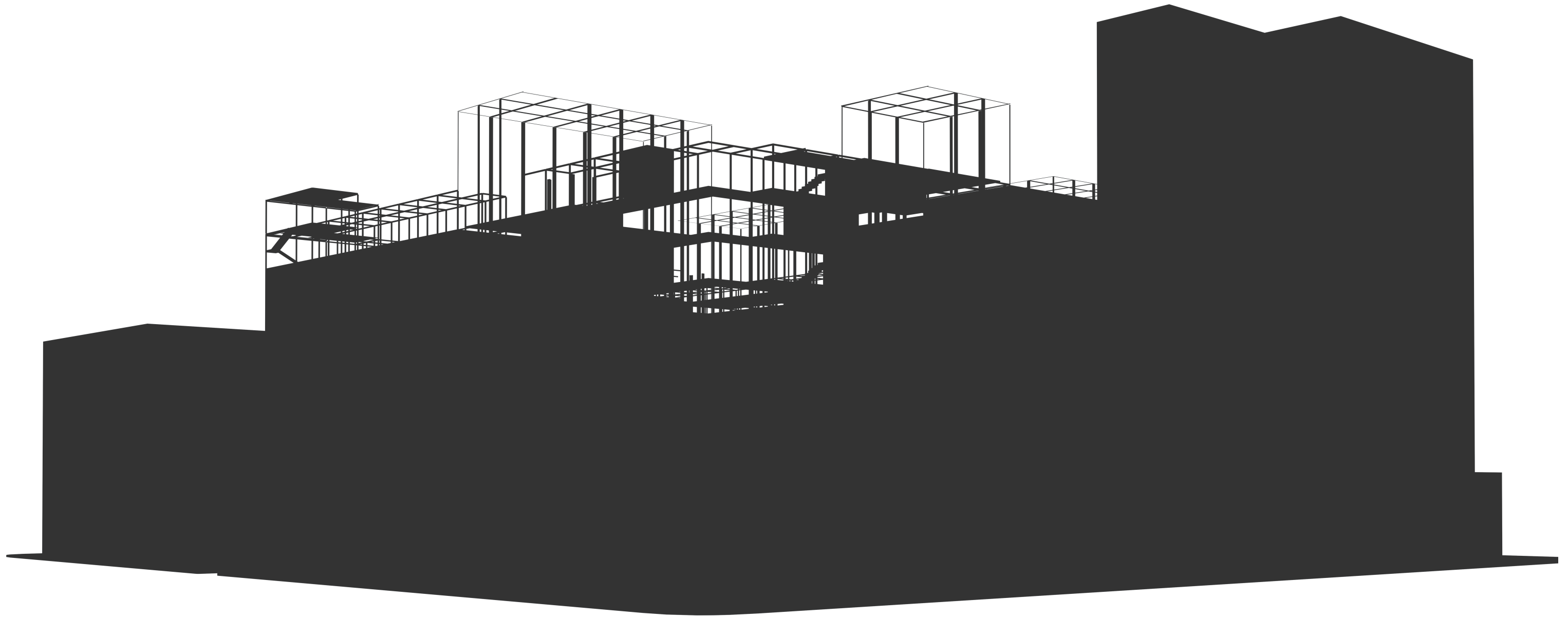



PLATAFORMA PARA LAS MULTIPLES ACTIVIDADES DE LA CIUDAD

Valoracion de los sitios vacantes Colectivo Publico-----Colectivo Privado

Un sistema adaptativo al cual le vamos a llamar artefacto que es capaz de disponerse mediante ciertas reglas de los terrenos logrando una **REGULACION VIRTUAL DEL VACIO** creando una estructura soportante el cual en su interior contiene **DISPOSITIVOS** los cuales portan los servicios para satisfacer estos distintos lugares.

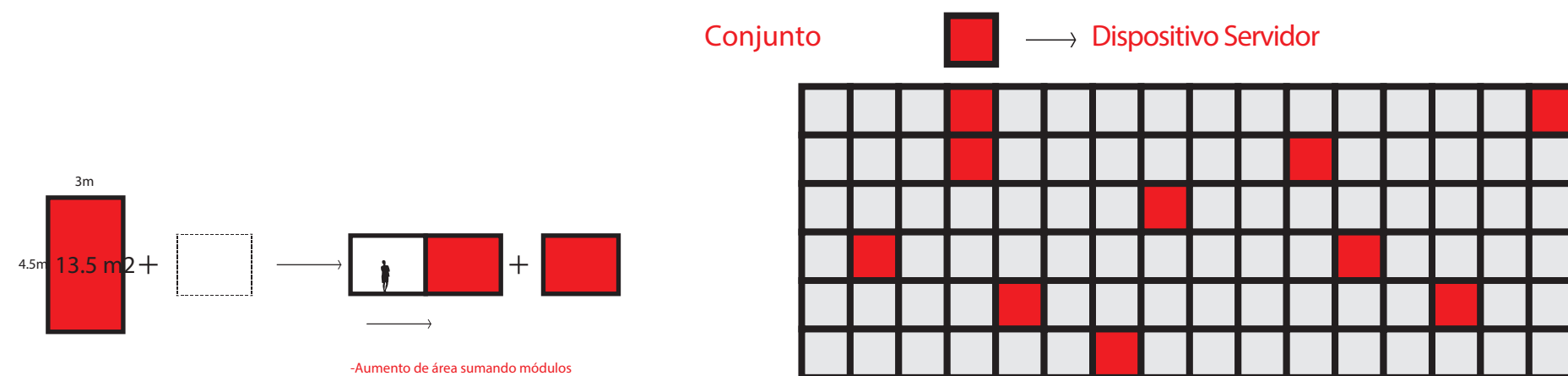
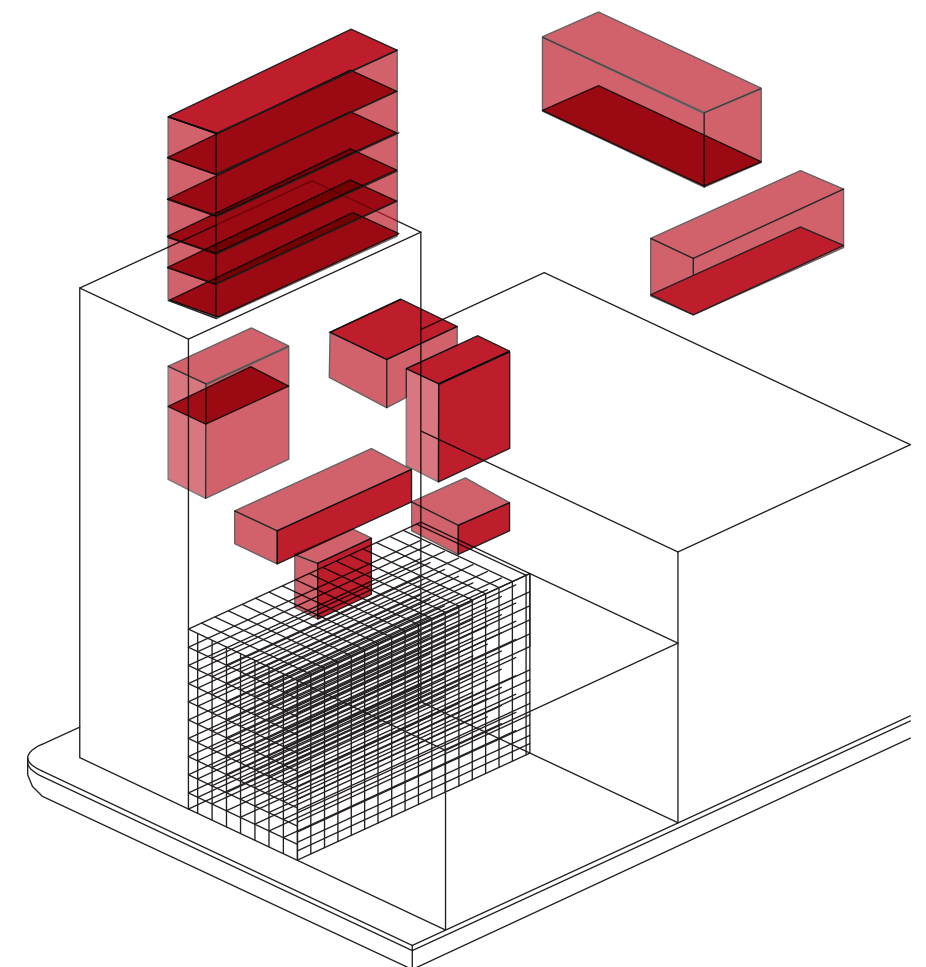

ARTEFACTO

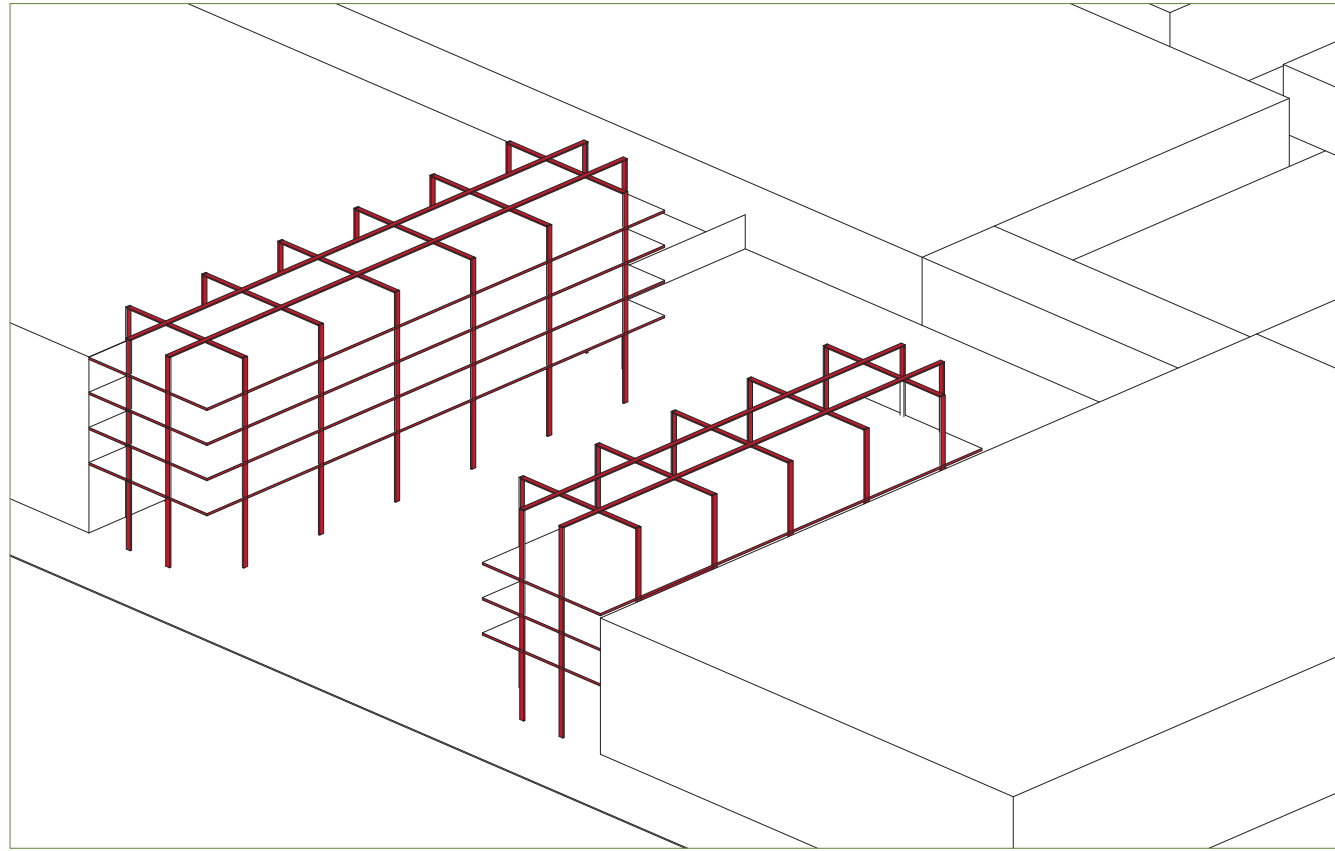

ADOSARSE A LOS MUROS CIEGOS

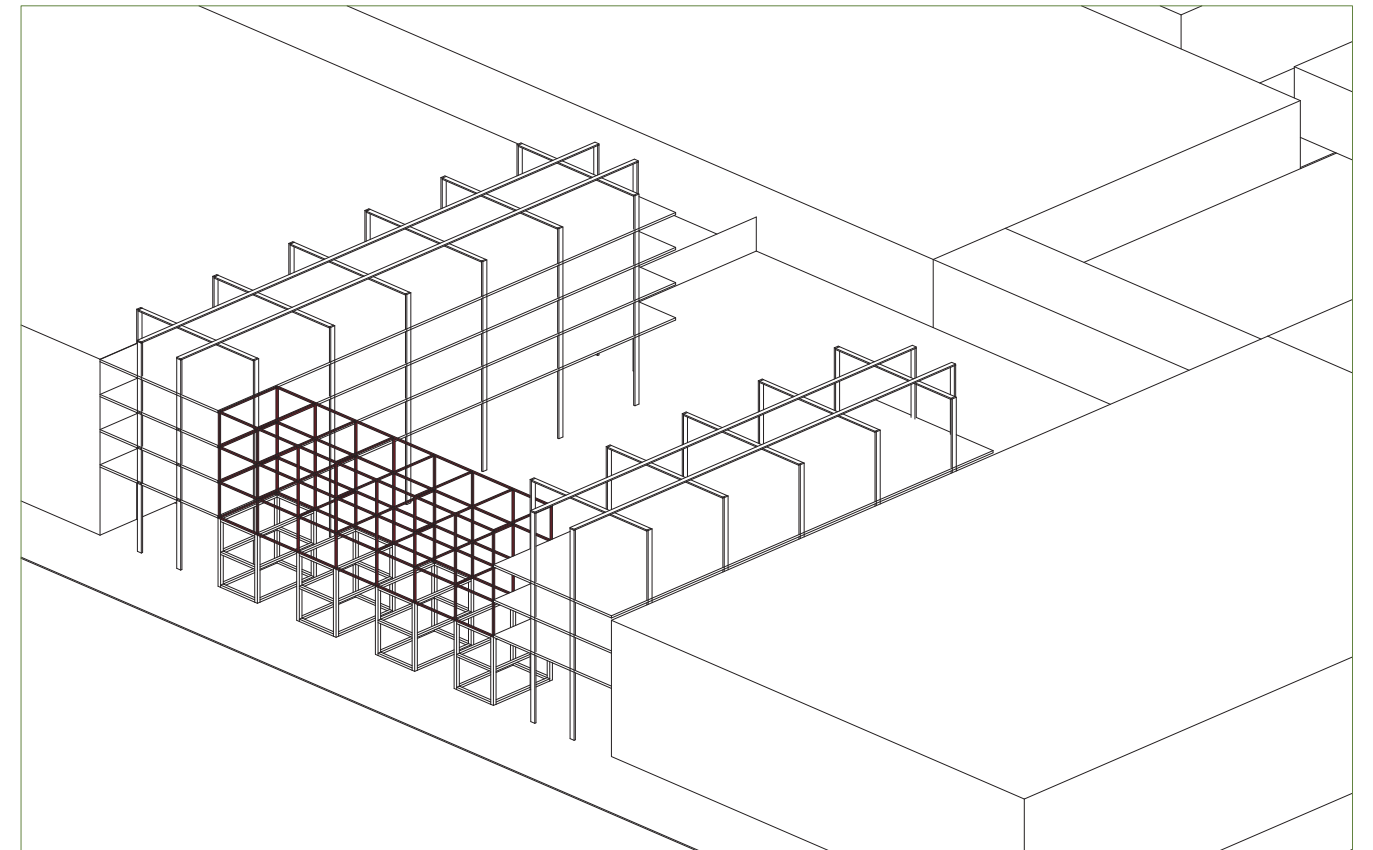

COMPLETAR LA ALTURA DE LA MANZANA

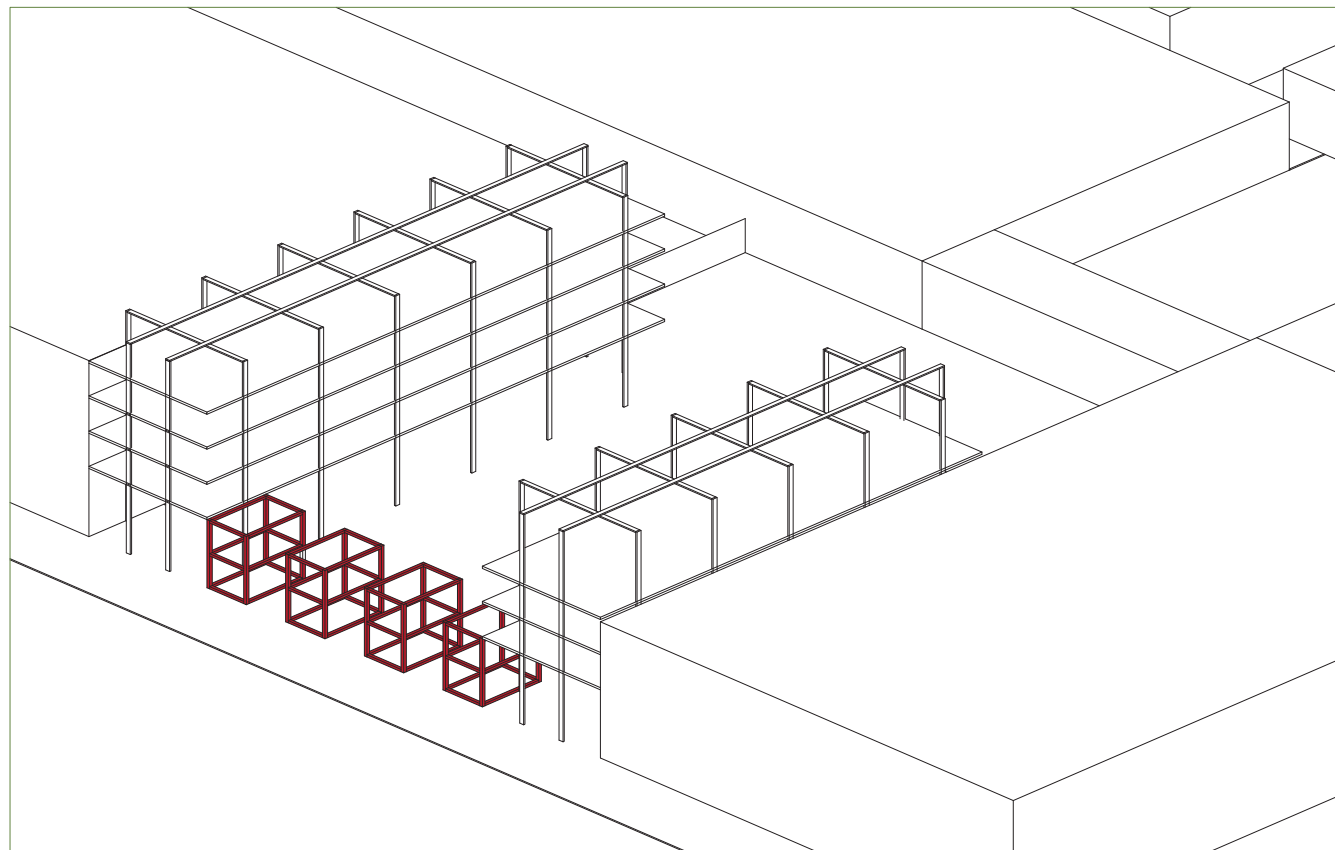

CONTENER ESPACIOS CON SERVICIOS

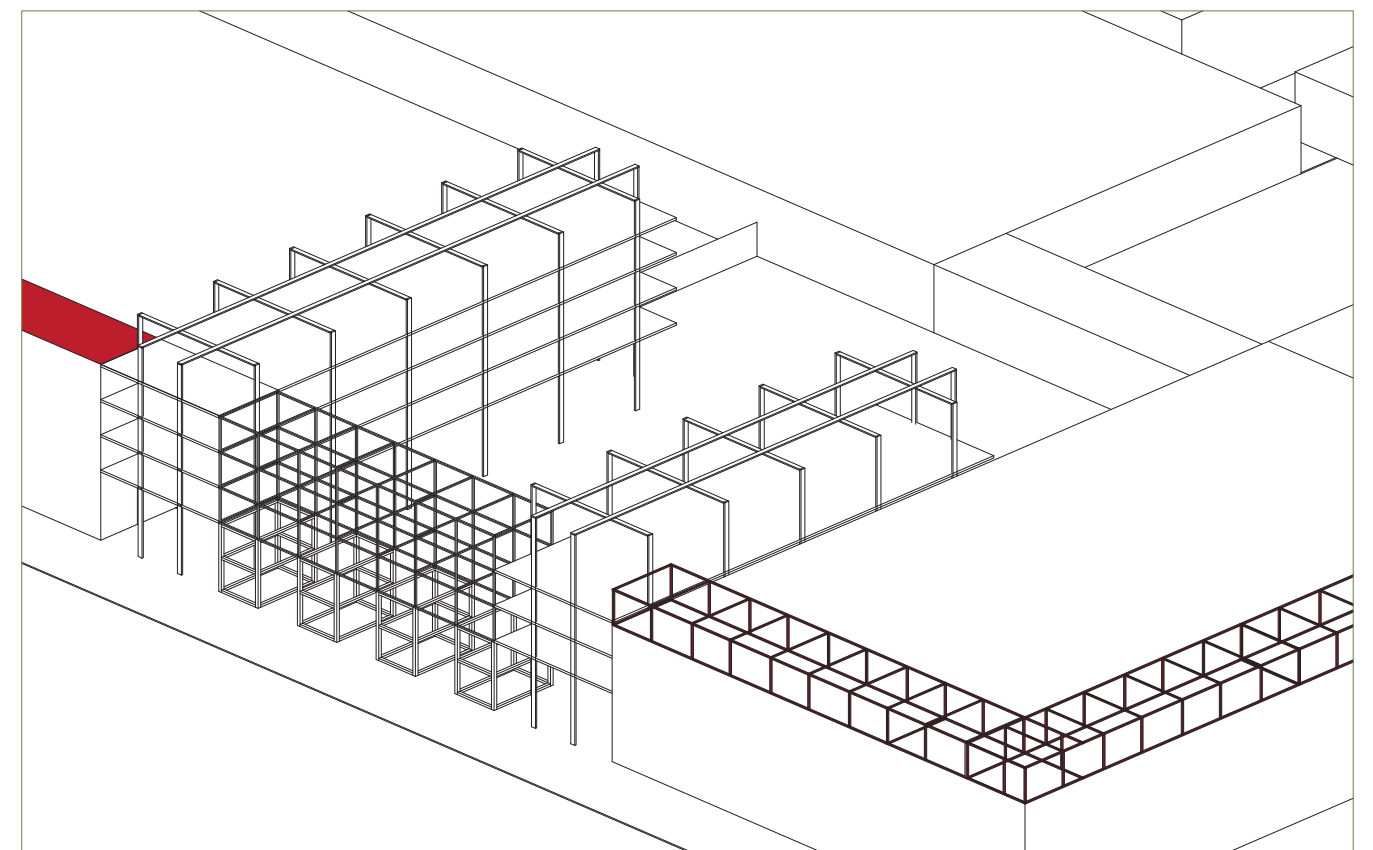

CONEXION CON EDIFICIOS DE LA MANZANA

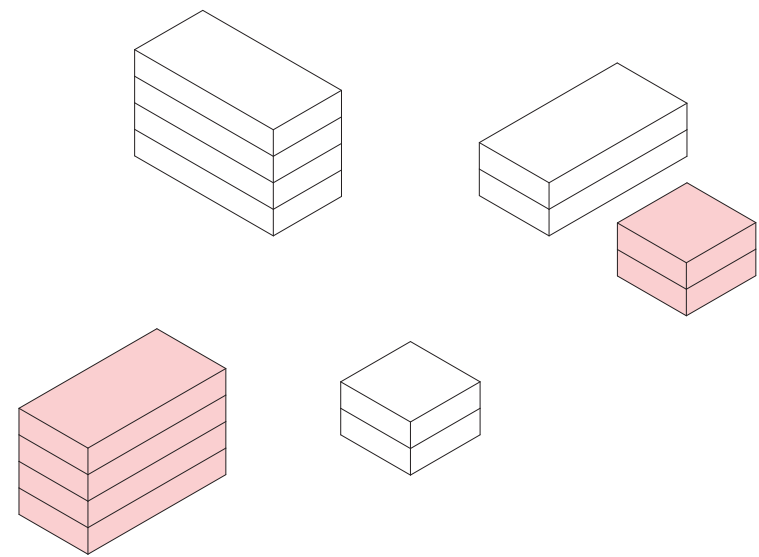

Espacios de Uso

Gimnasio
Flesta
Talleres
Exhibicion
Auditorio

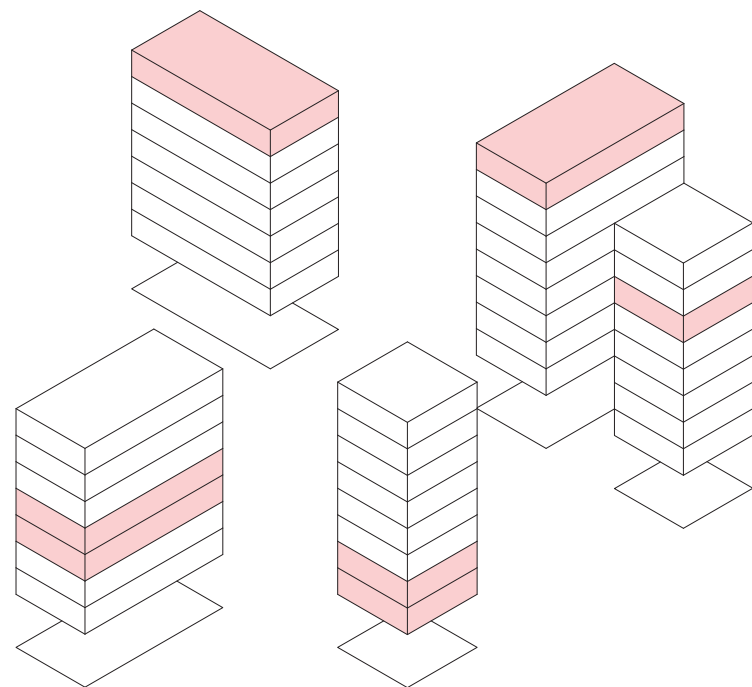

Programas de Extension

Salas Multiuso
Mediateca
Biblioteca
Laboratorios
Gimnasio
Escenario

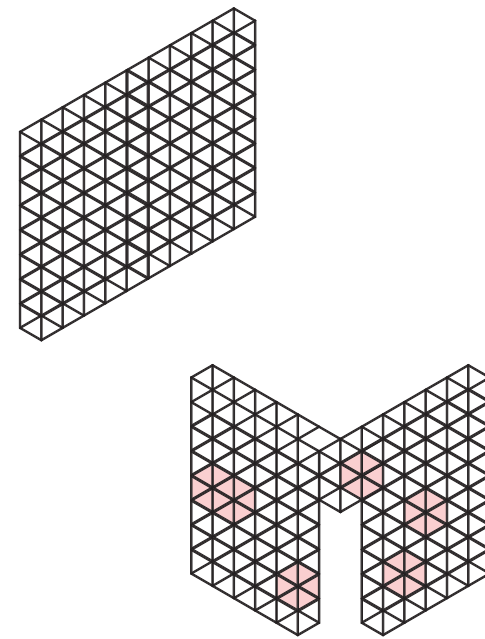

Servicios Programa de Extension

Baños
Bodegas
Tecnologia
Descanzo
Ocio
Informacion
Estudio
Boxs
Utiles

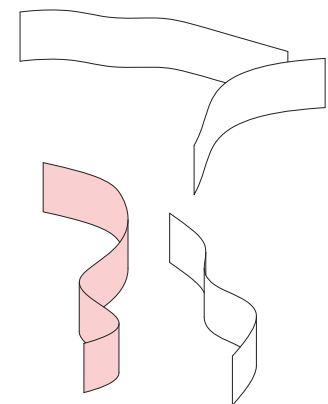

Cintas Cualificadoras

Intercambio Cultural
Intercambio Comercial
Permutacion
Interaccion
Mutualidad
Adicion

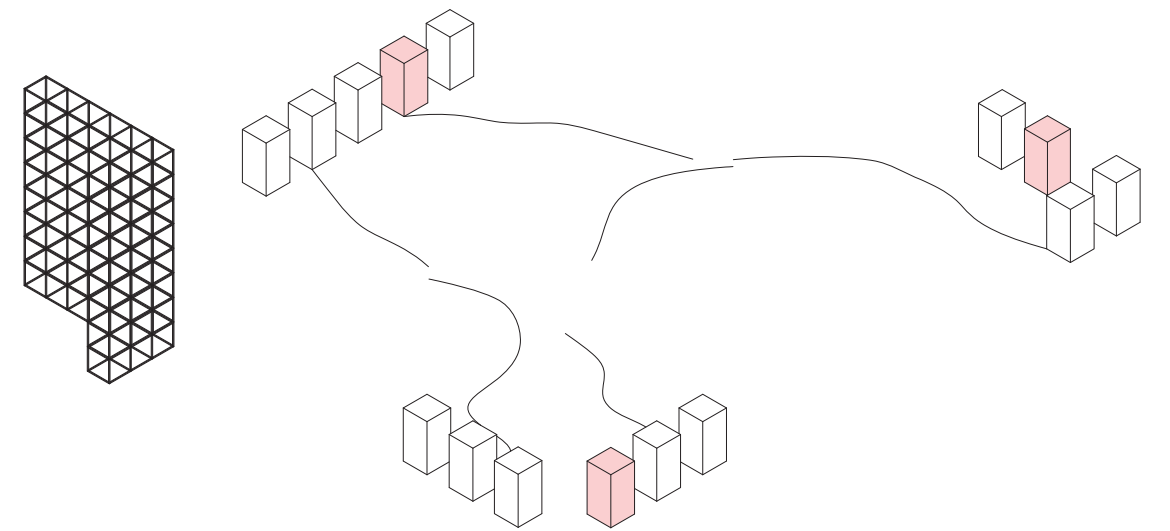

Programas de Apoyo

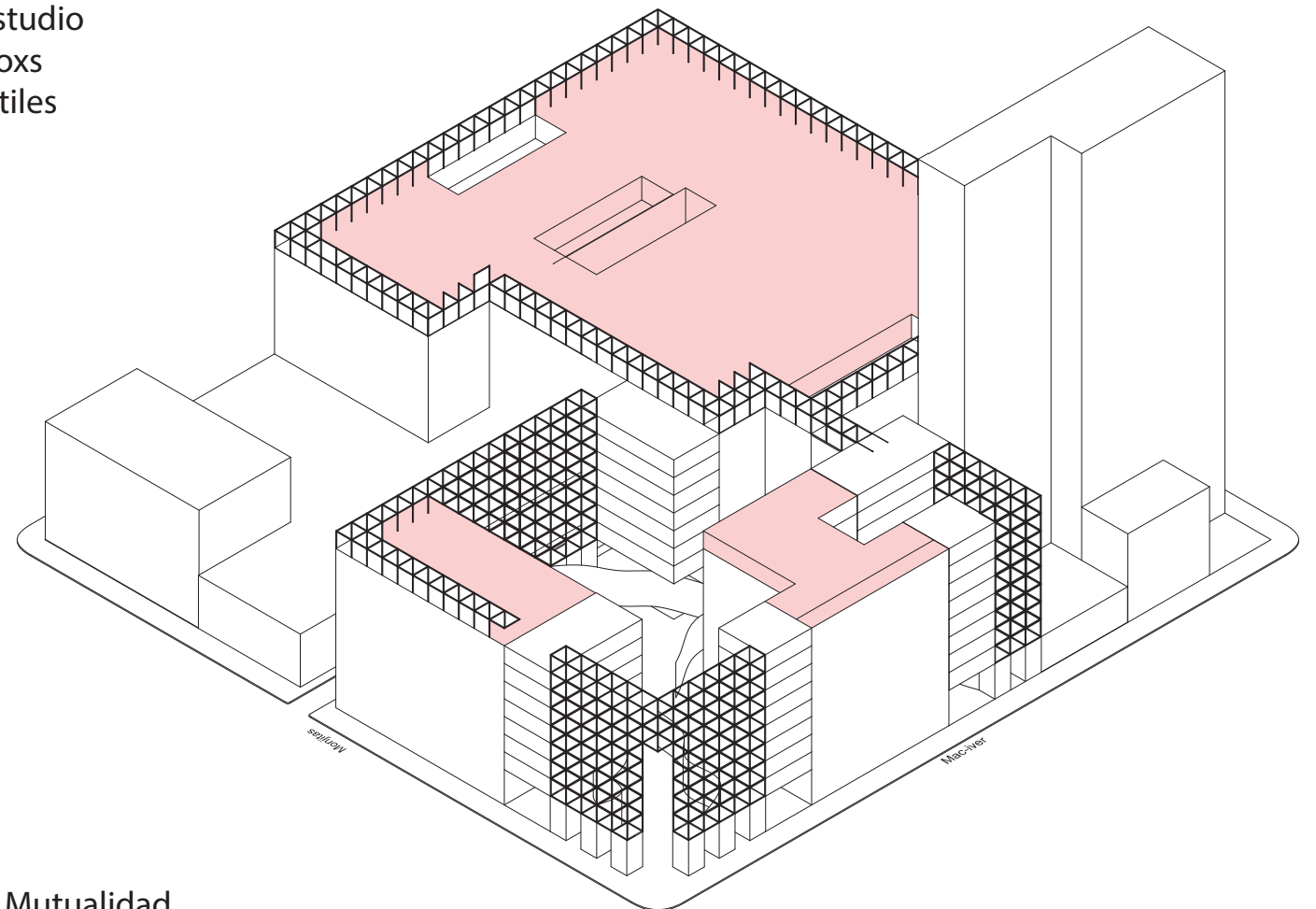

Patios C.E.U



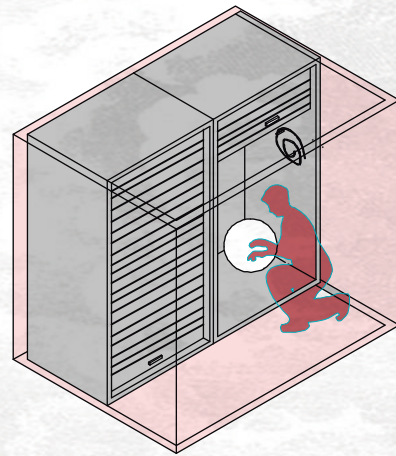
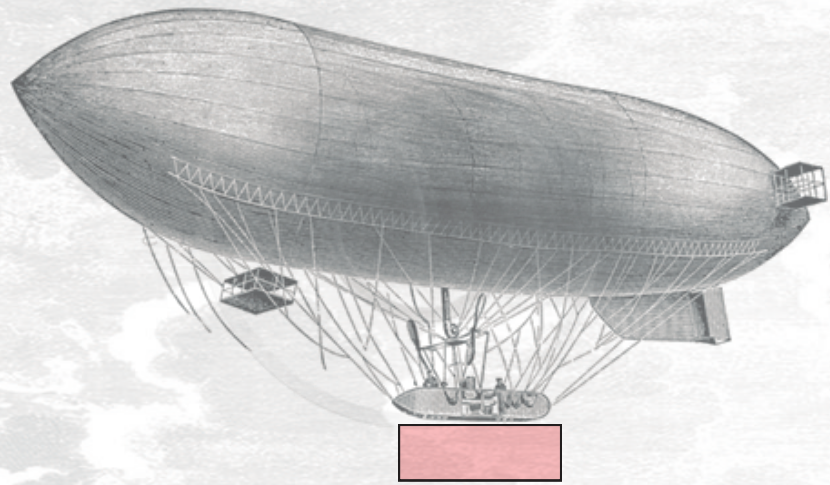

DISPOSITIVO
BODEGA



DISPOSITIVO
BAÑOS

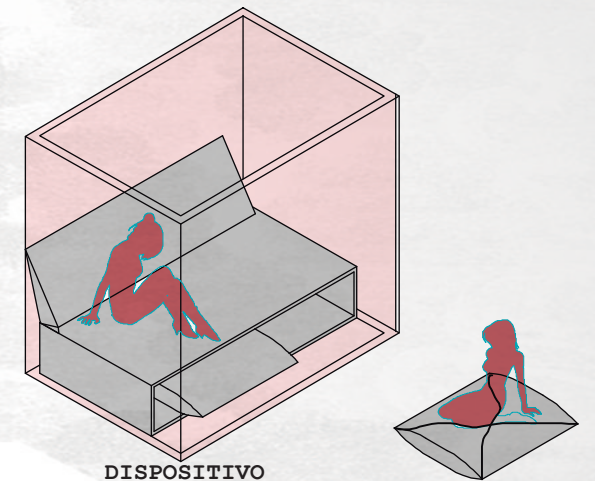

DISPOSITIVO
COJINES

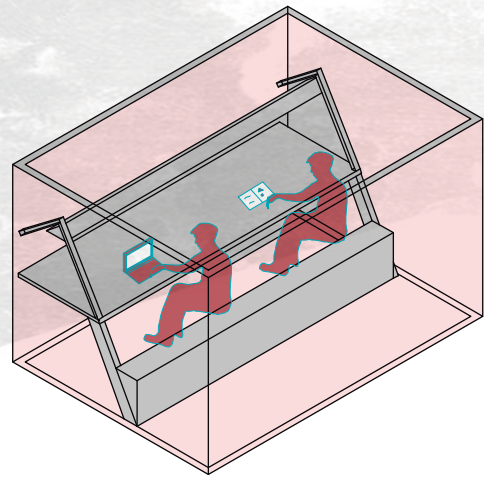

DISPOSITIVO
MESA

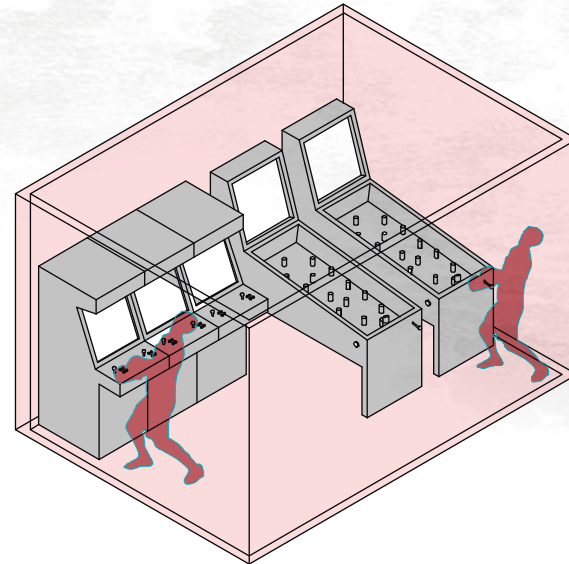

DISPOSITIVO
OCIO

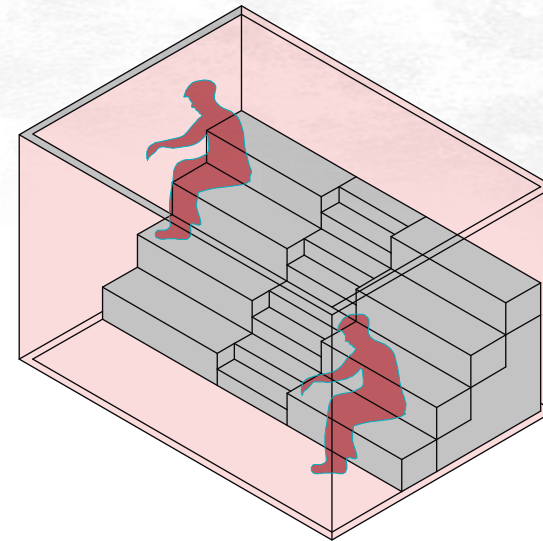

DISPOSITIVO
GALERIA

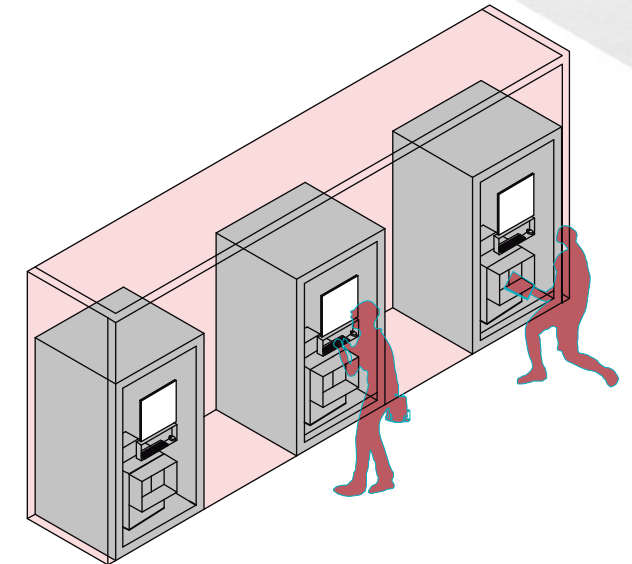

DISPOSITIVO
IMPRESION

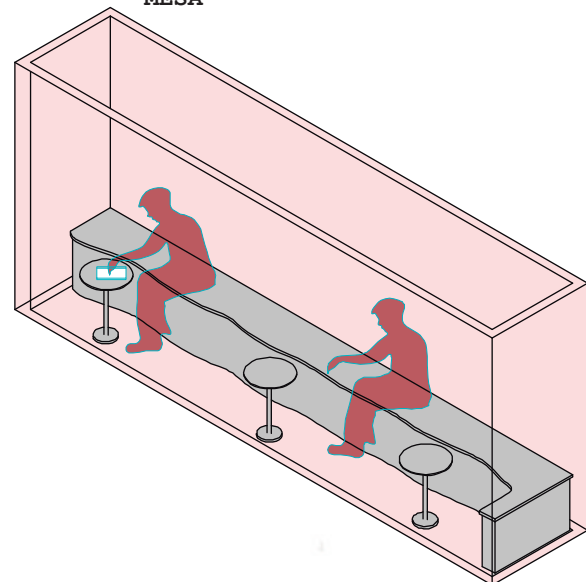

DISPOSITIVO

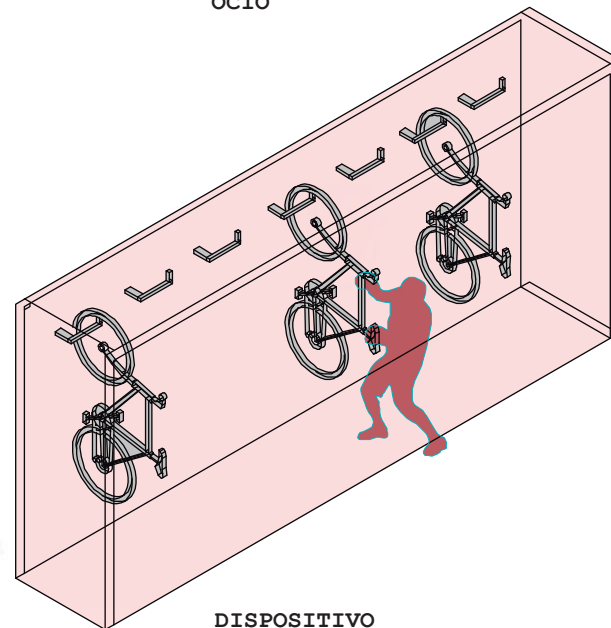

DISPOSITIVO
BICICLETAS

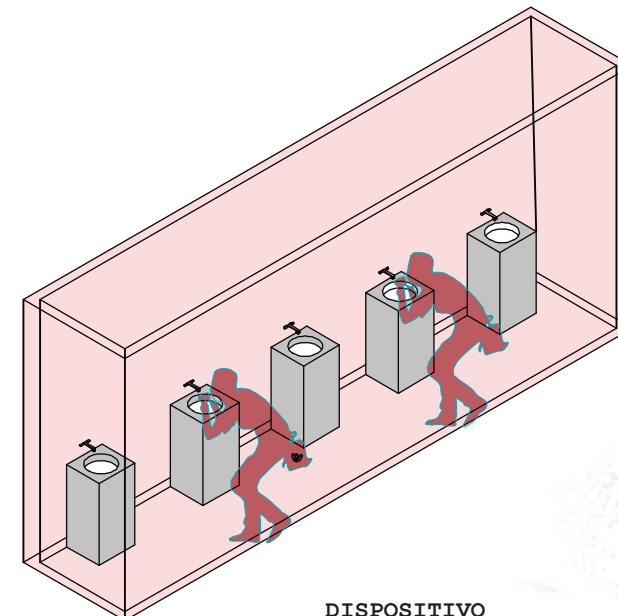

DISPOSITIVO
BEBEDEROS

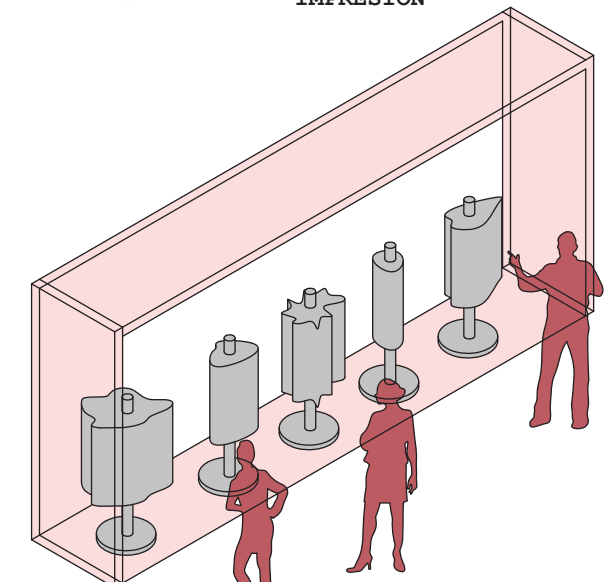

DISPOSITIVO
EXHIBICION

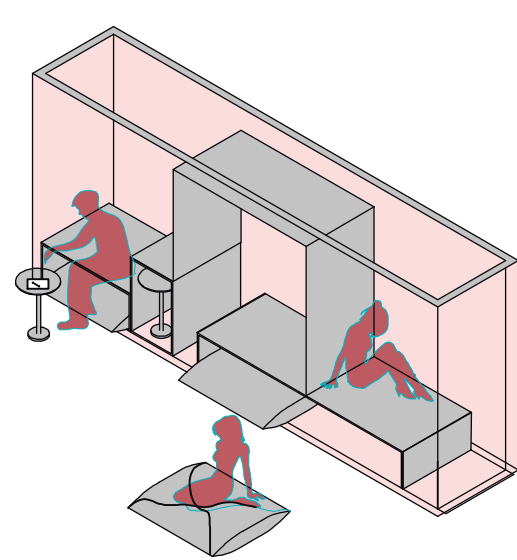

DISPOSITIVO
DESCANSO

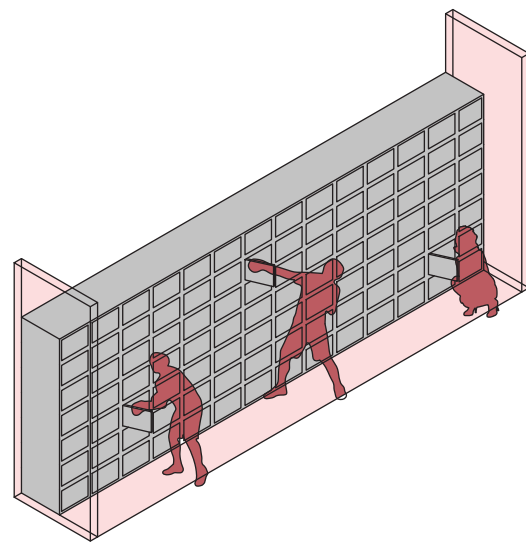

DISPOSITIVO
LOCKERS

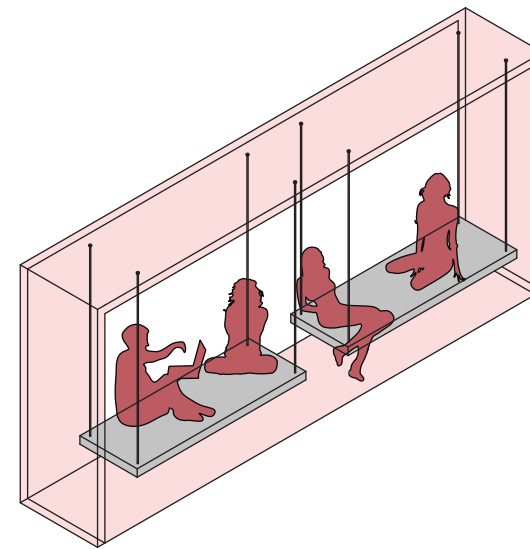

DISPOSITIVO
MESEDOR

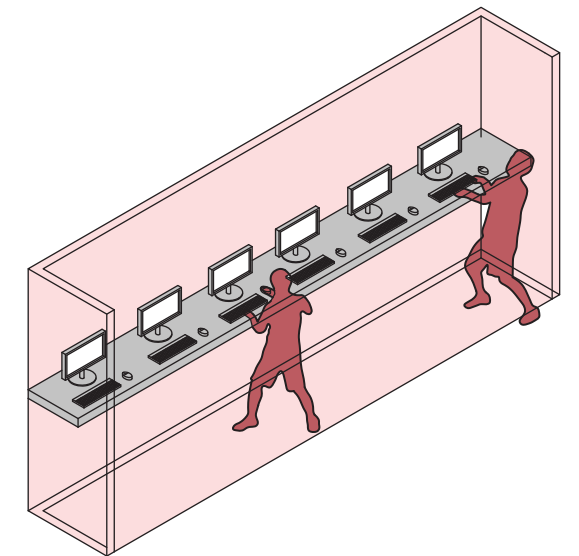

DISPOSITIVO
CONECTIVIDAD

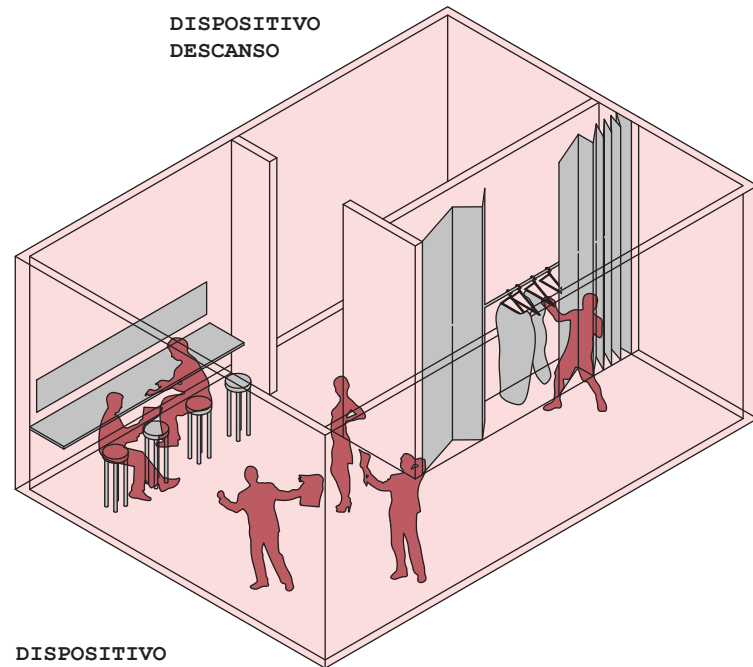

DISPOSITIVO
VESTUARIO

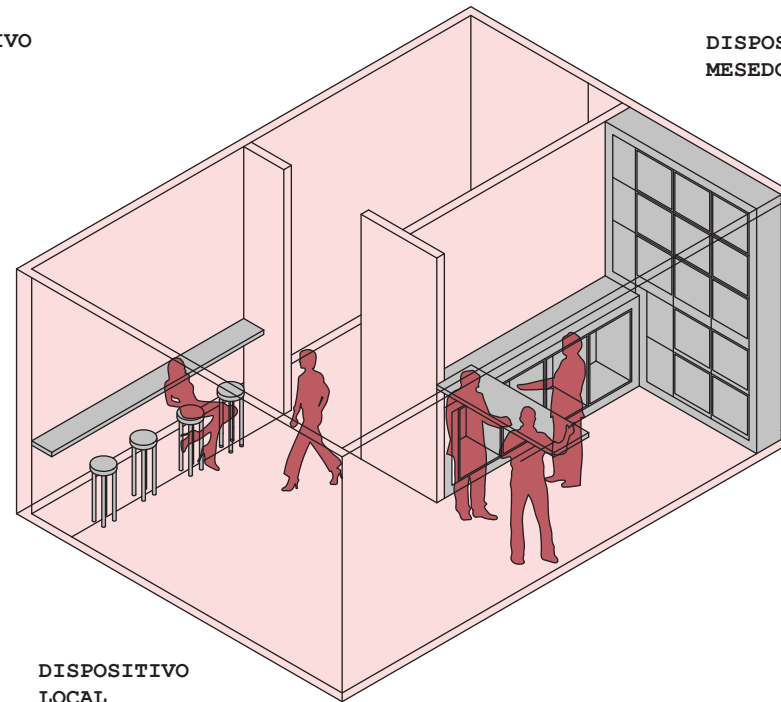

DISPOSITIVO
LOCAL

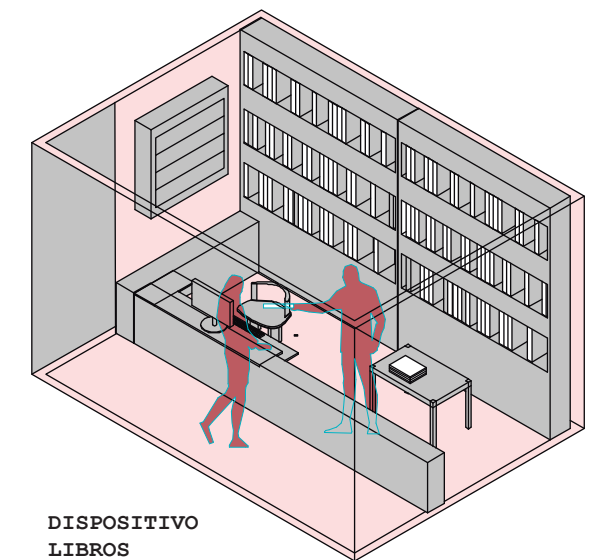

DISPOSITIVO
LIBROS

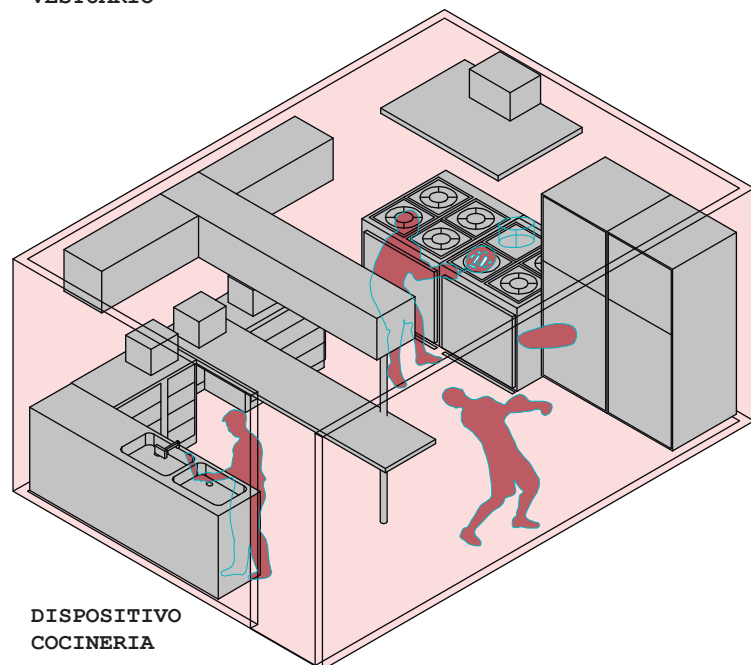

DISPOSITIVO
COCINERIA

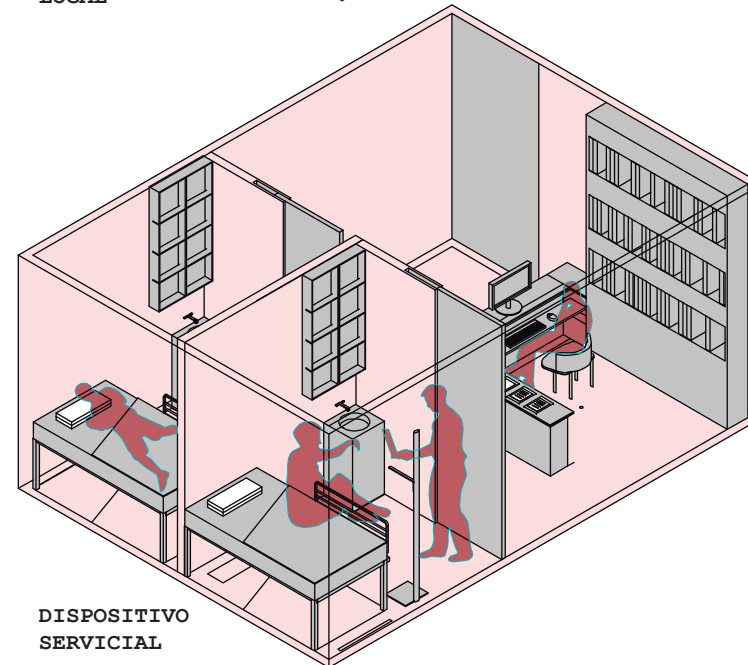

DISPOSITIVO
SERVICIAL

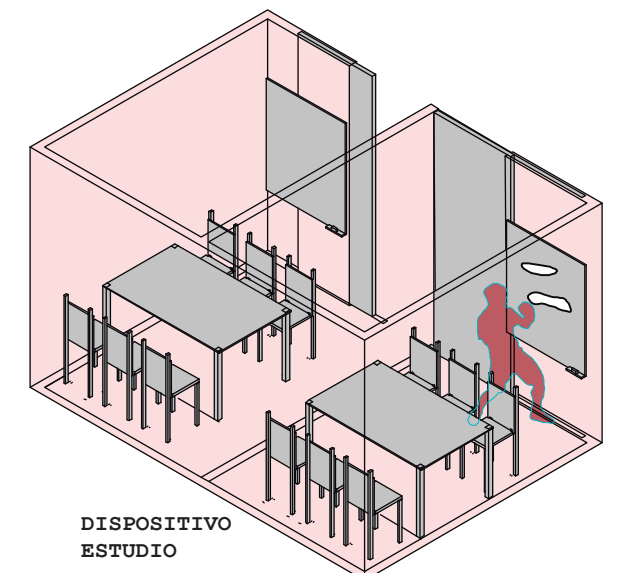

DISPOSITIVO
ESTUDIO



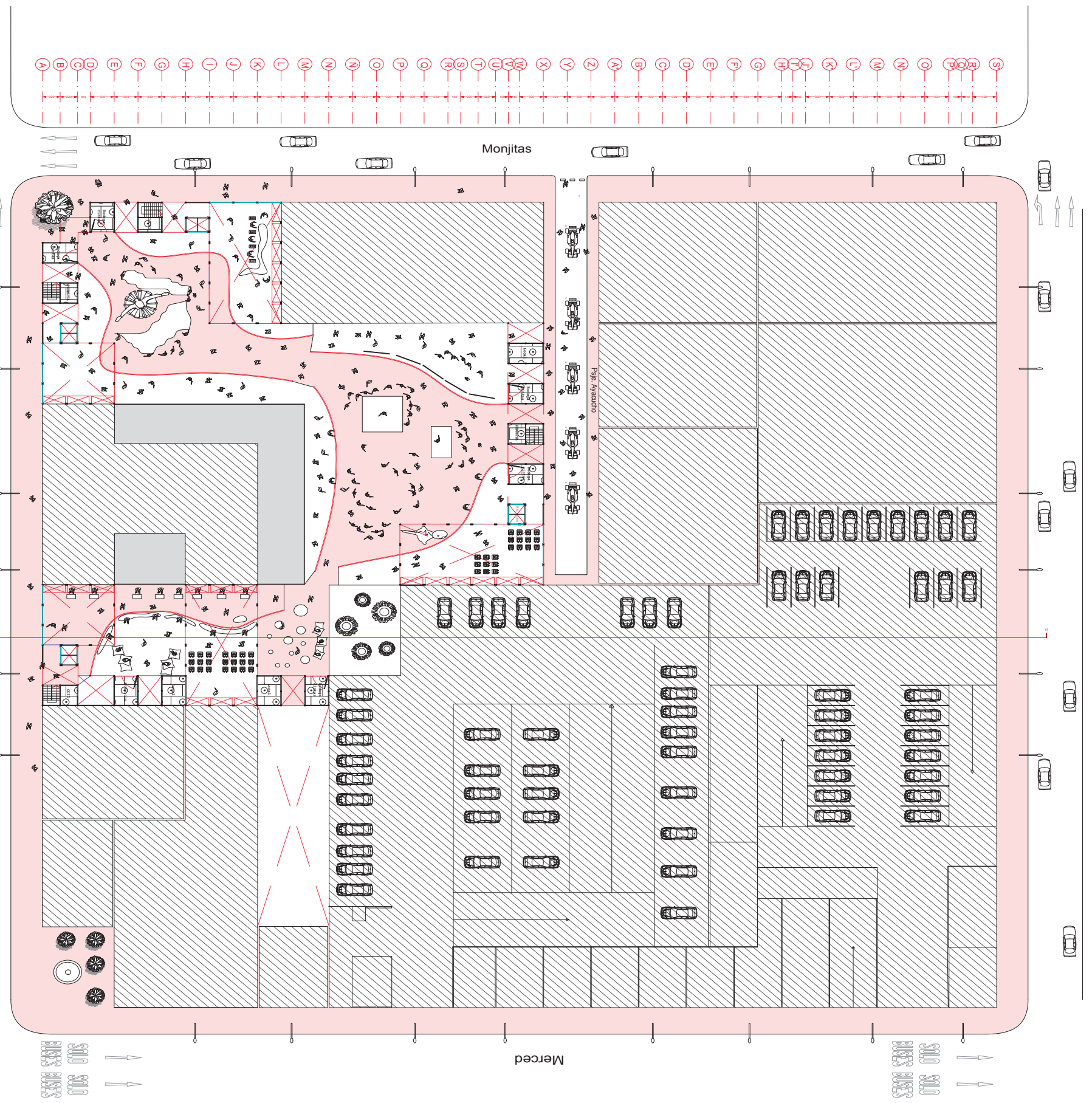

PLANTA NIVEL CALLE COLECTIVO - PUBLICO
 ESCALA 1:200 Intercambio permutacion interaccion mutualidad Adicion



CORTE
 B - B"
 ESCALA 1:175

- 1
- 2
- 3
- 4
- 5
- 6
- 7
- 8
- 9
- 10
- 11
- 12
- 13
- 14
- 15
- 16
- 17
- 18
- 19
- 20
- 21
- 22
- 23
- 24
- 25
- 26
- 27
- 28
- 29
- 30
- 31
- 32
- 33
- 34
- 35
- 36
- 37
- 38
- 39
- 40
- 41
- 42
- 43
- 44
- 45
- 46
- 47
- 48
- 49
- 50
- 51

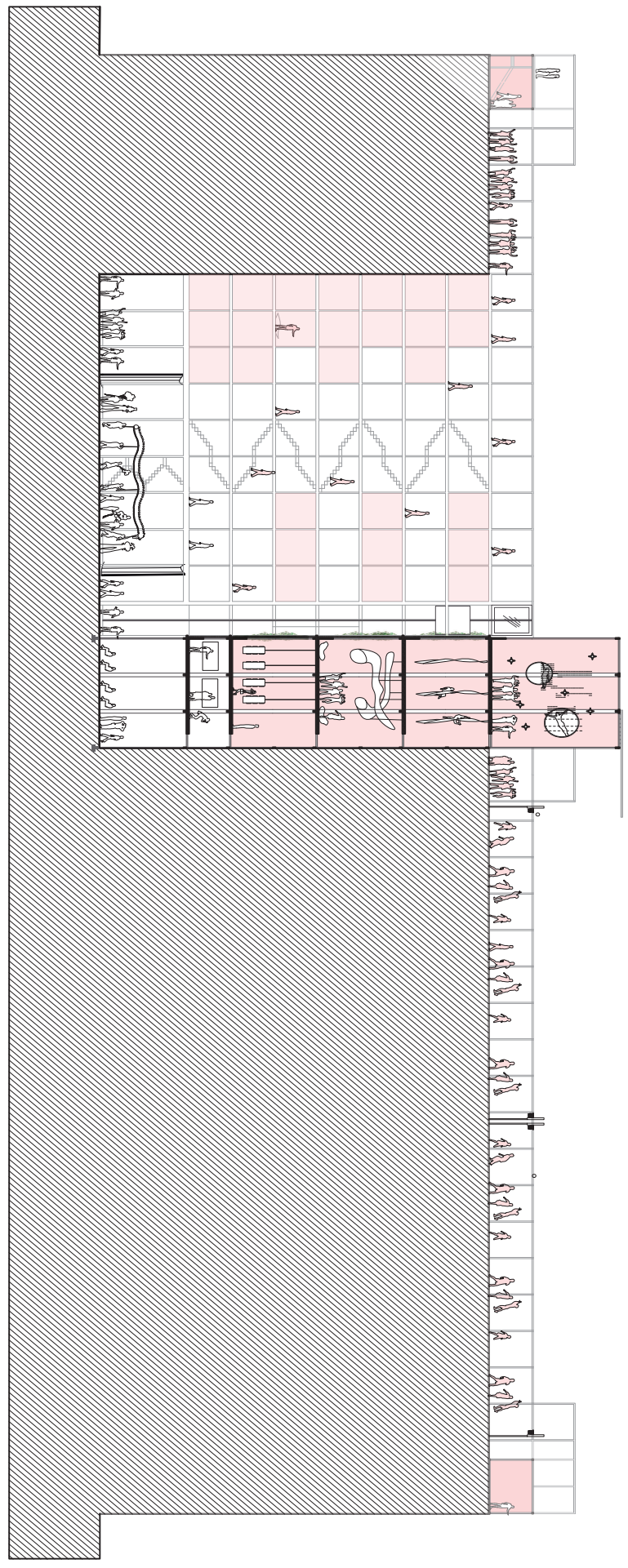

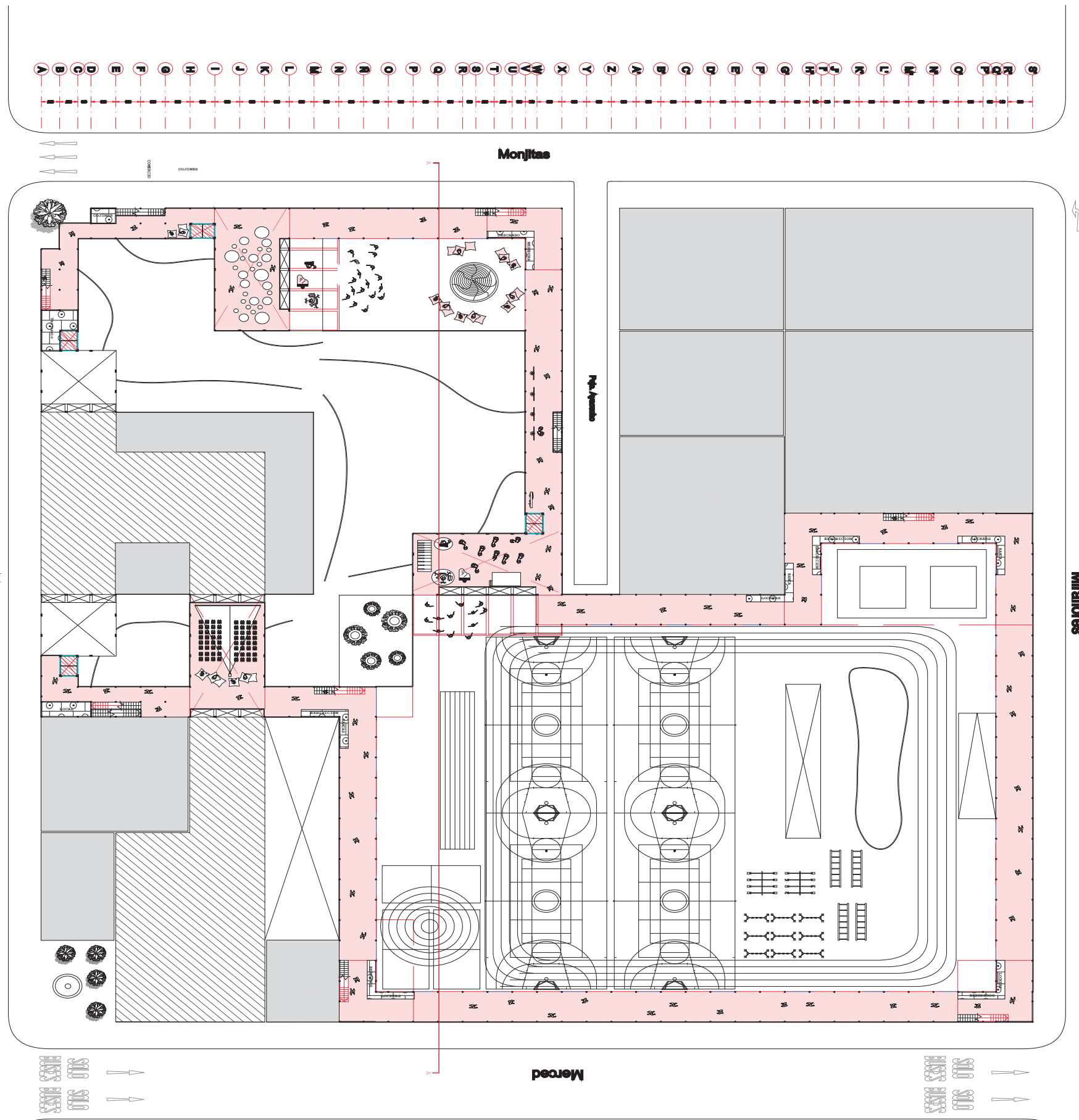

PLANTA NIVEL PLAZAS COLECTIVO - PRIVADO
 ESCALA 1:200 N 10
 Deporte Espectaculo Espacio Beneficiario

CORTE
 A - A"
 ESCALA 1:175

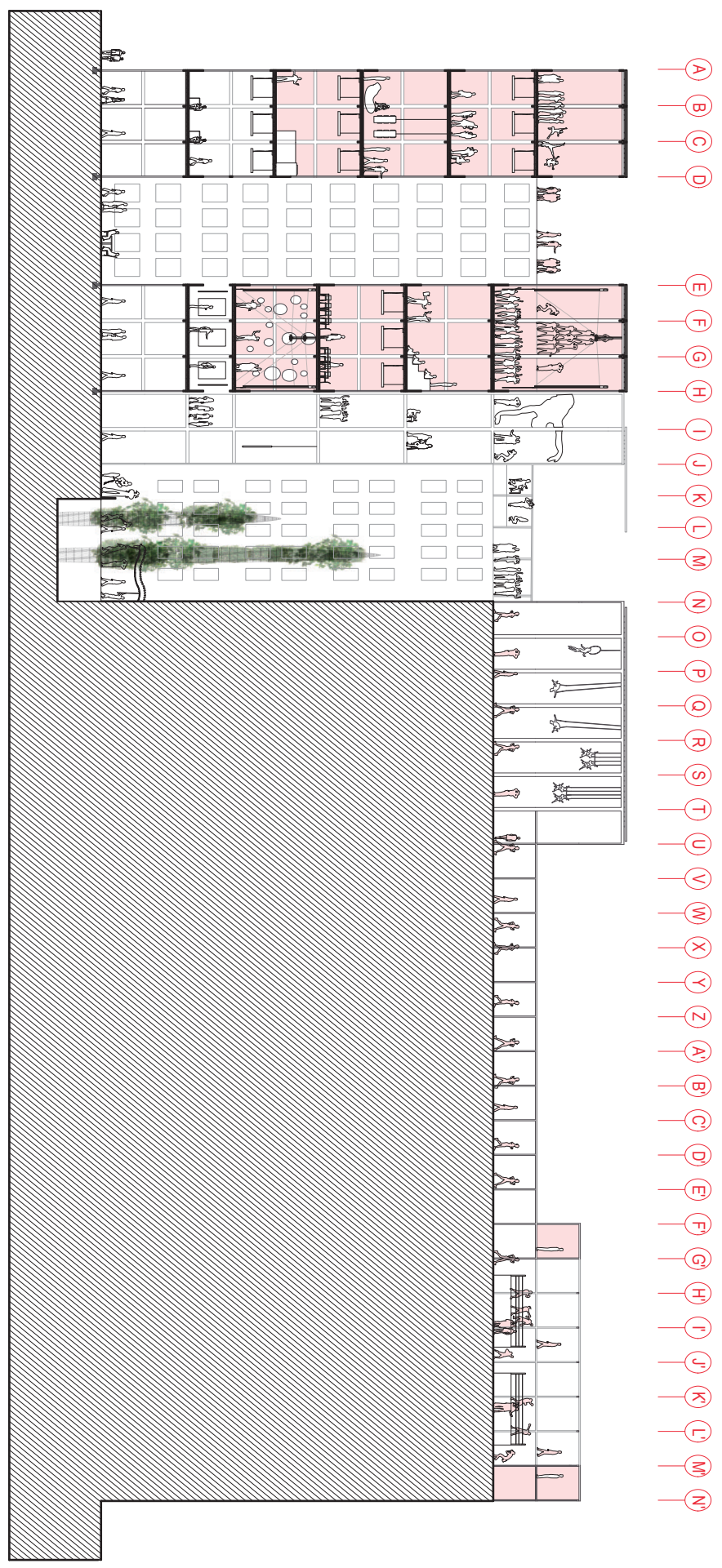

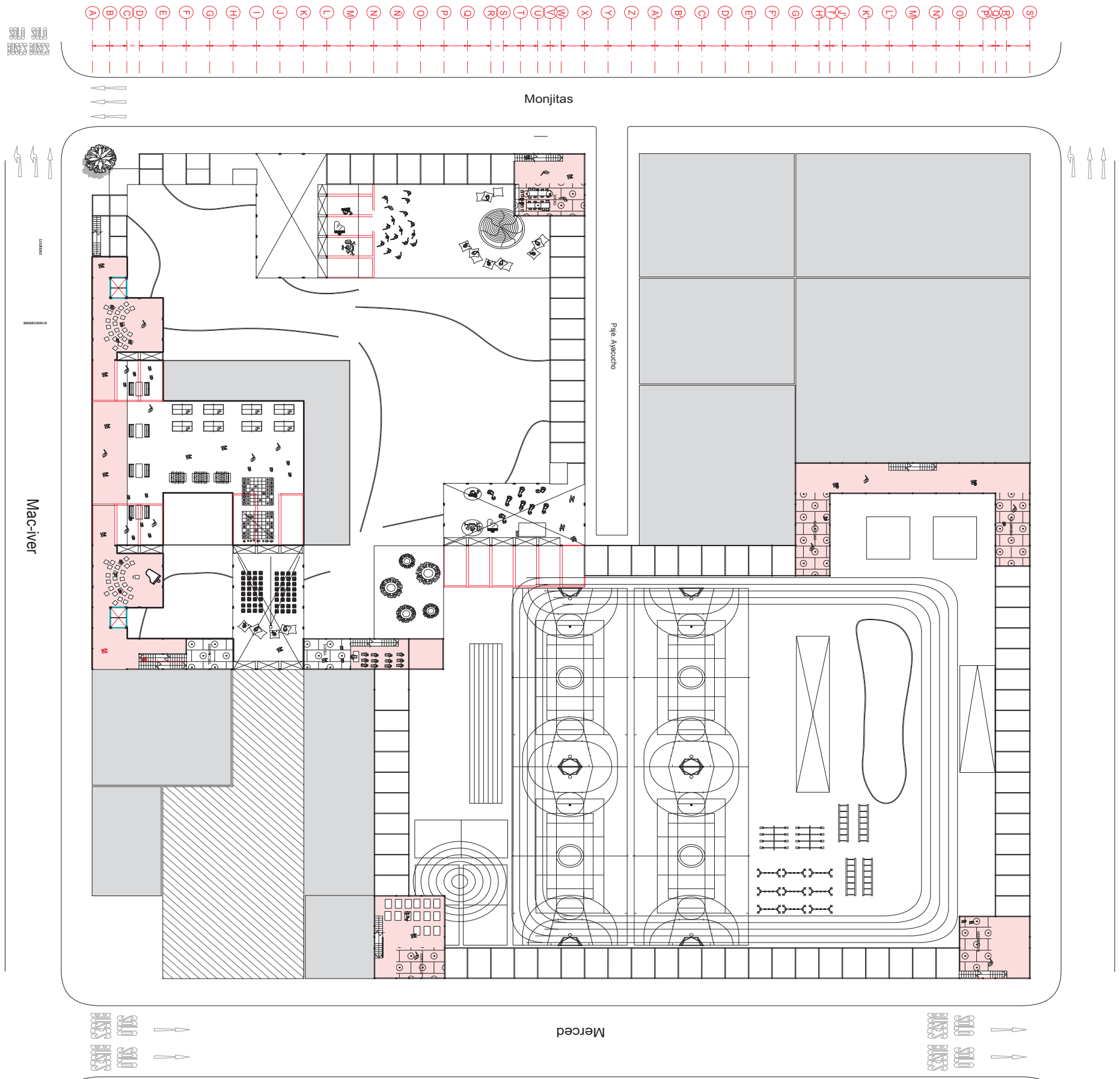

PLANTA NIVEL 11
 ESCALA 1:200

COLECTIVO - PRIVADO
 Espacios de apoyo Plaza intercambio cultural

ELEVACION MONJITAS
 ESCALA 1:175

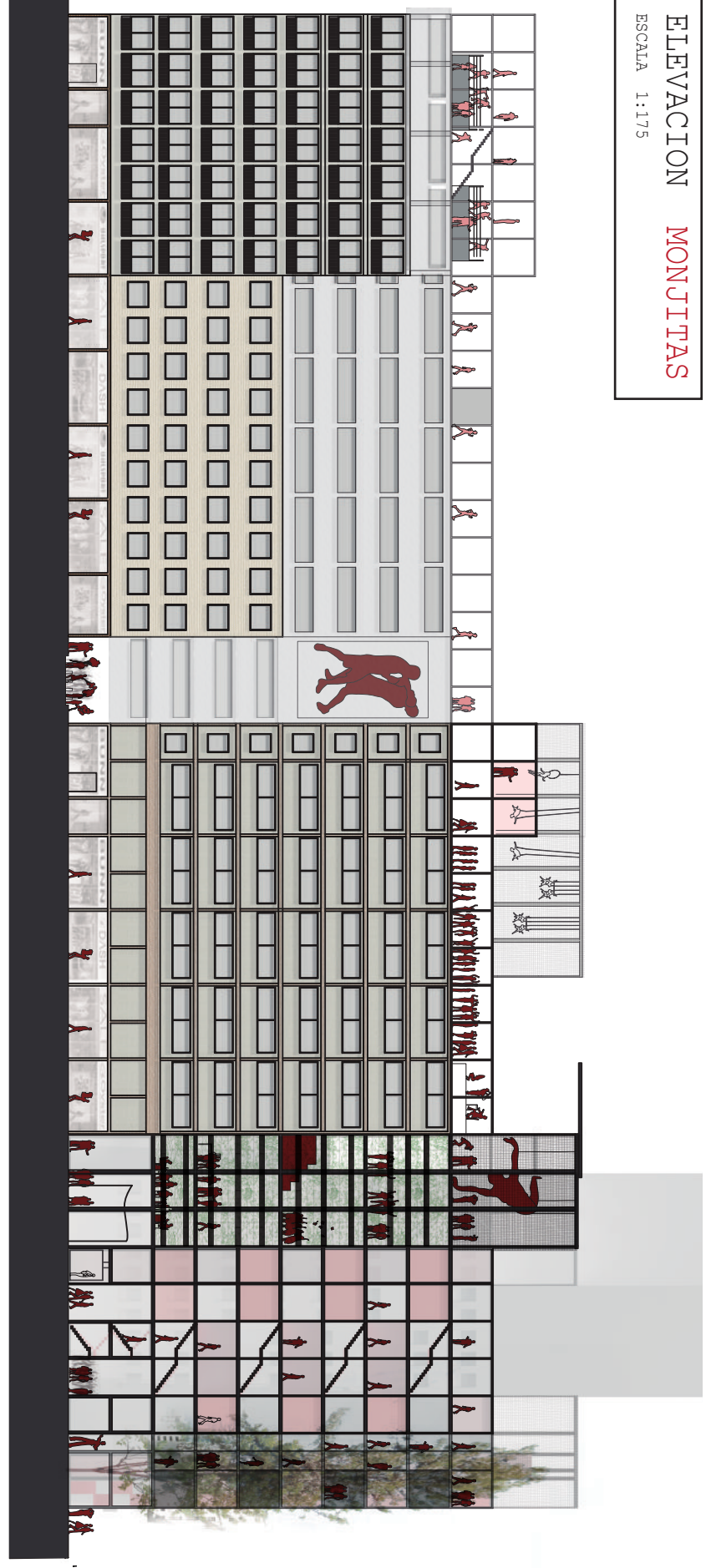
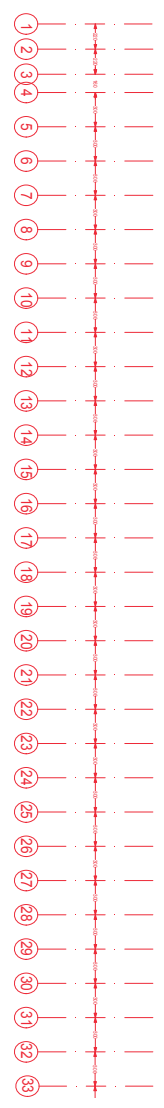

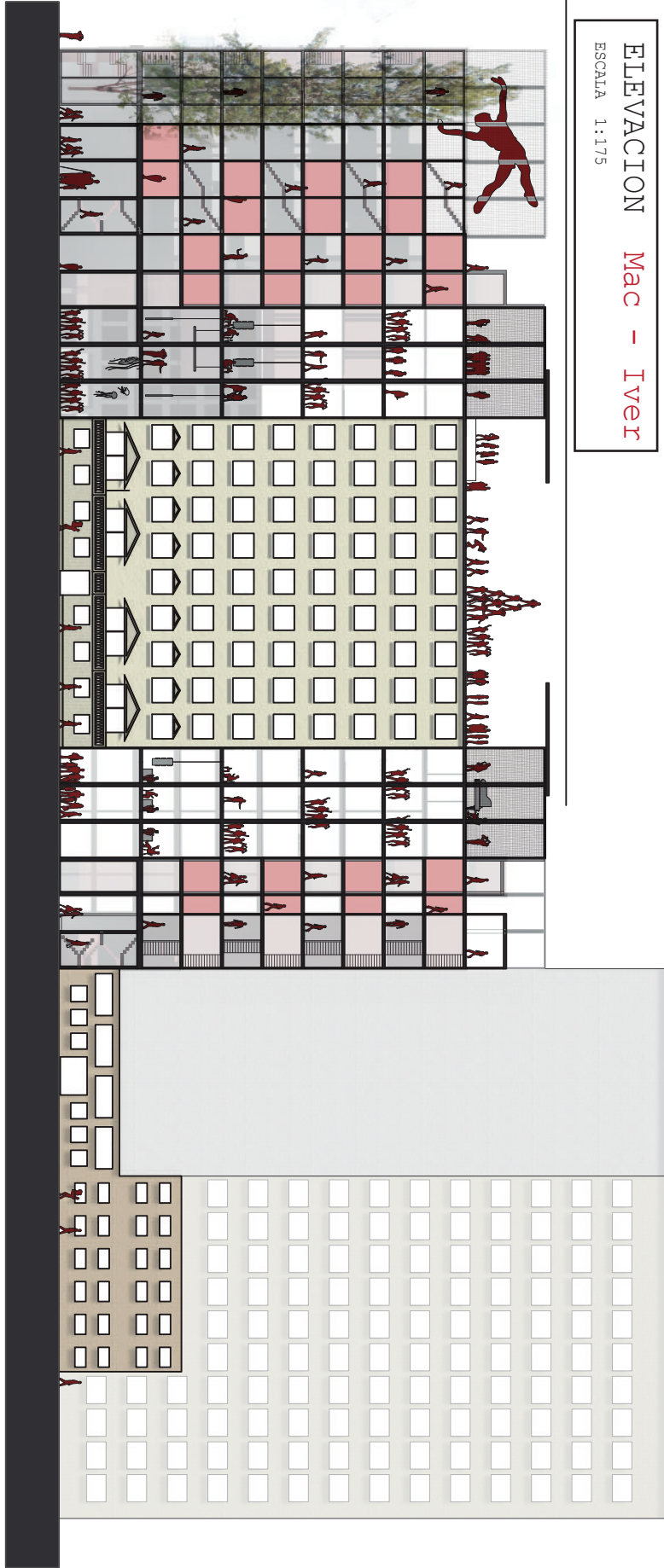

ELEVACION Mac - Iver
ESCALA 1:175

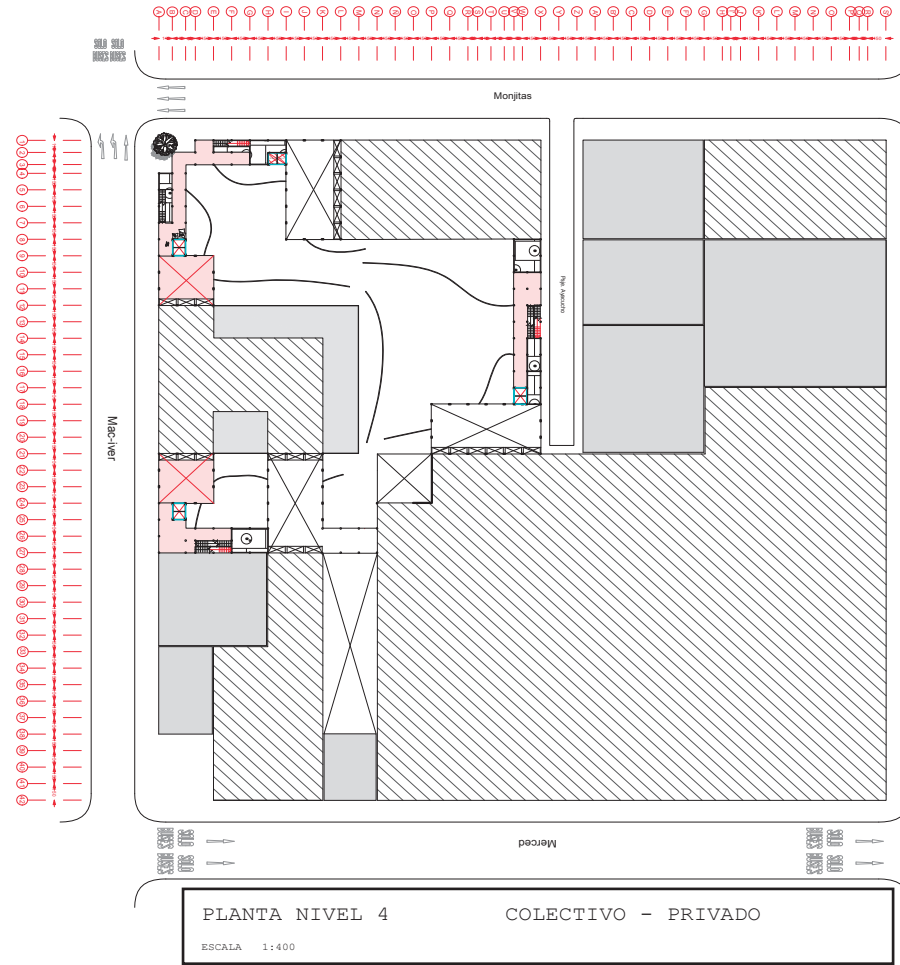

PLANTA NIVEL 4 COLECTIVO - PRIVADO

ESCALA 1:400

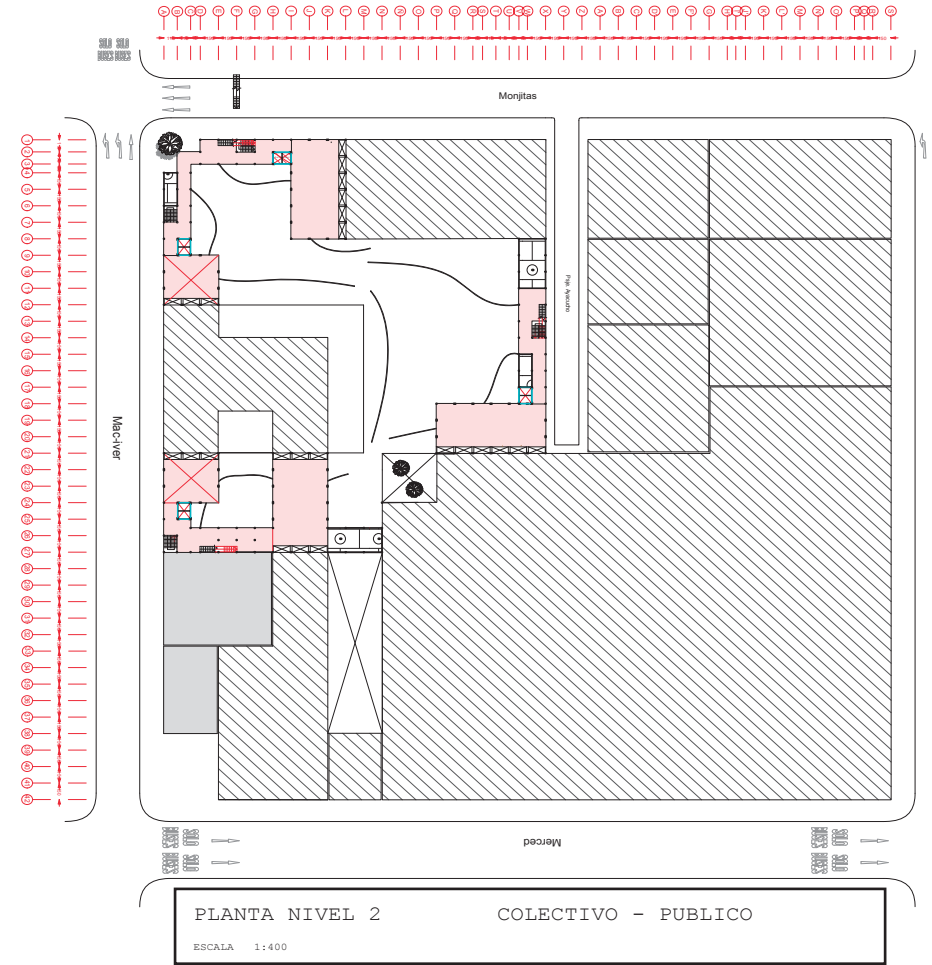

PLANTA NIVEL 2 COLECTIVO - PUBLICO

ESCALA 1:400

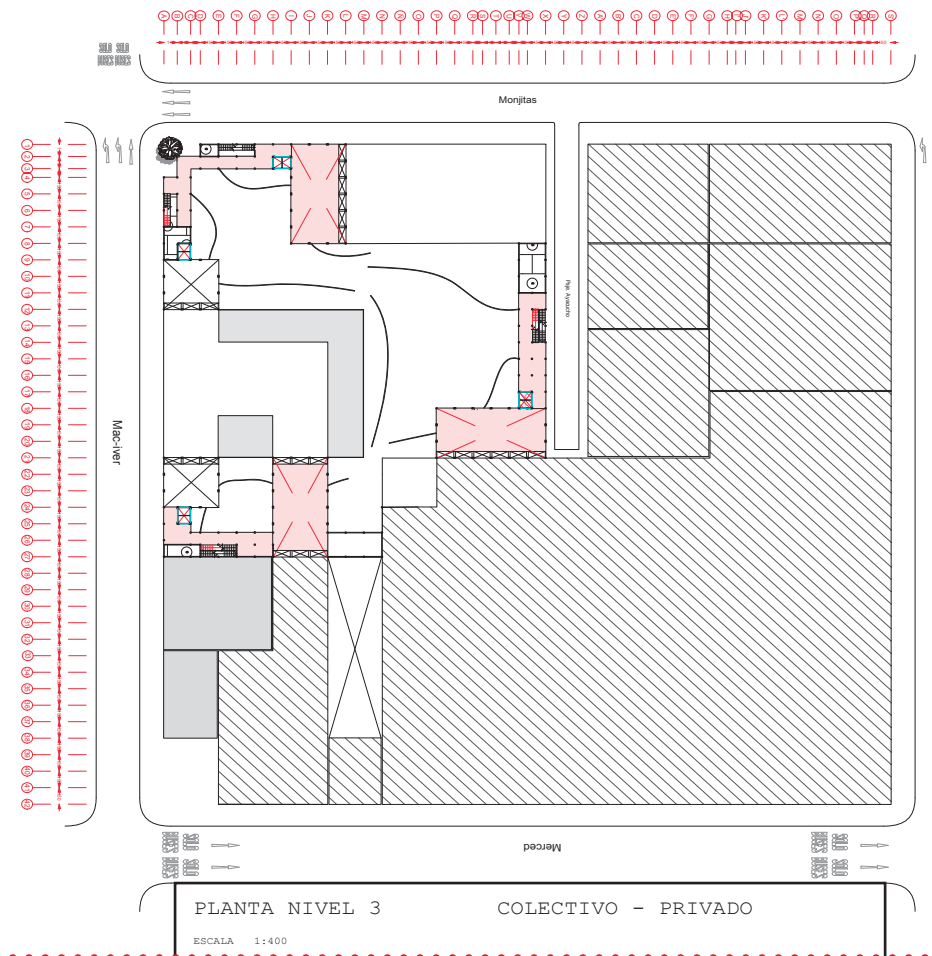

PLANTA NIVEL 3 COLECTIVO - PRIVADO

ESCALA 1:400

